

URBAN-RESIDENTIAL AND BUSINESS

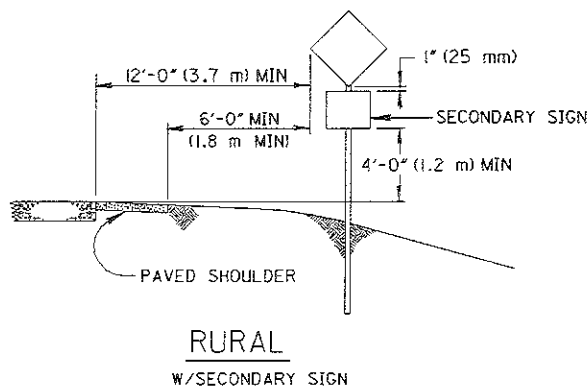

RURAL
W/SECONDARY SIGN

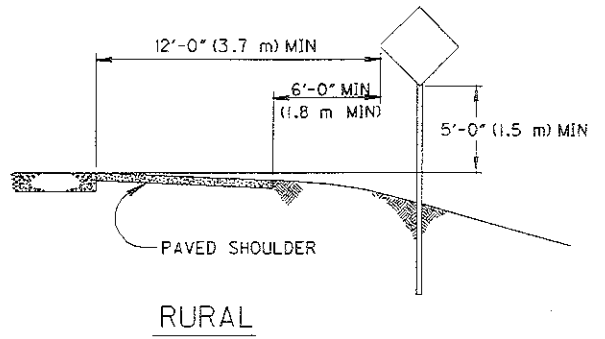

RURAL

NOTES

1. See drawing TC-41.20 for details on yielding supports.
2. All signs shall be placed 90° to the roadway, except parking signs with arrow shall be set at an angle of not less than 30° nor more than 45° with a line parallel to the flow of traffic.
3. A clearance of 1 foot (0.3 m) is permissible where sidewalk width is limited or where existing poles are close to the curb.
4. See drawings TC-52.10 and TC-52.20 for dimensions between supports.

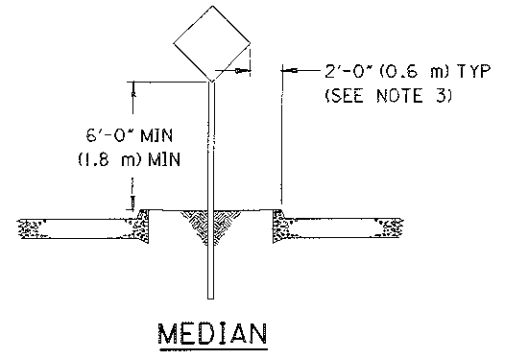

MEDIAN

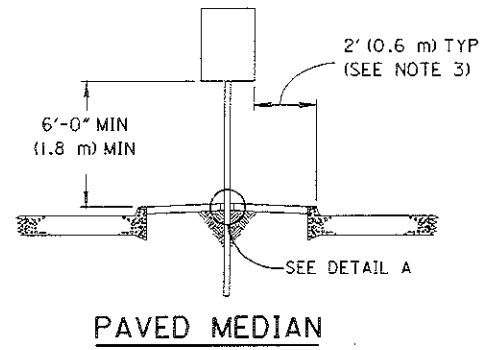

PAVED MEDIAN

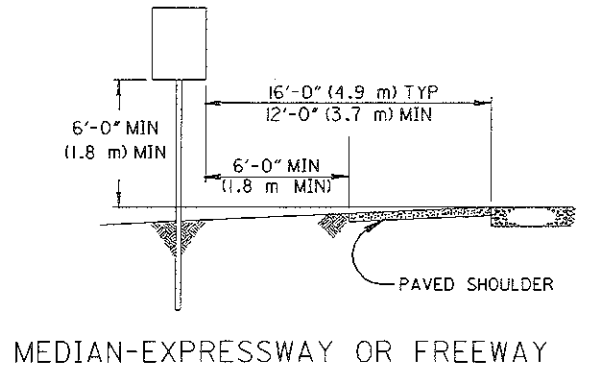

MEDIAN-EXPRESSWAY OR FREEWAY

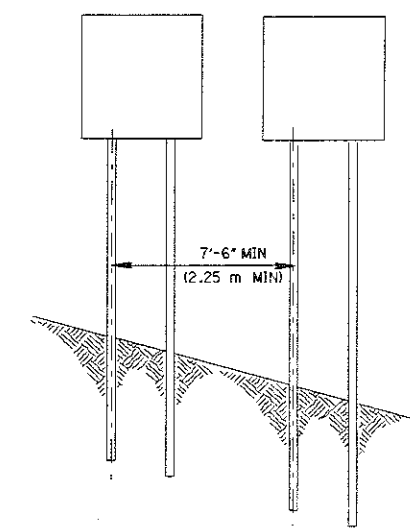

ADJACENT SIGN INSTALLATION

FOR NO. 2 AND NO. 3 YIELDING POST SUPPORTS IN EXPOSED LOCATIONS

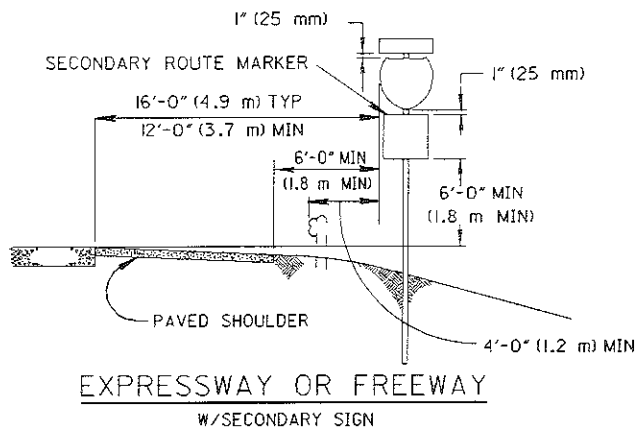

EXPRESSWAY OR FREEWAY
W/SECONDARY SIGN

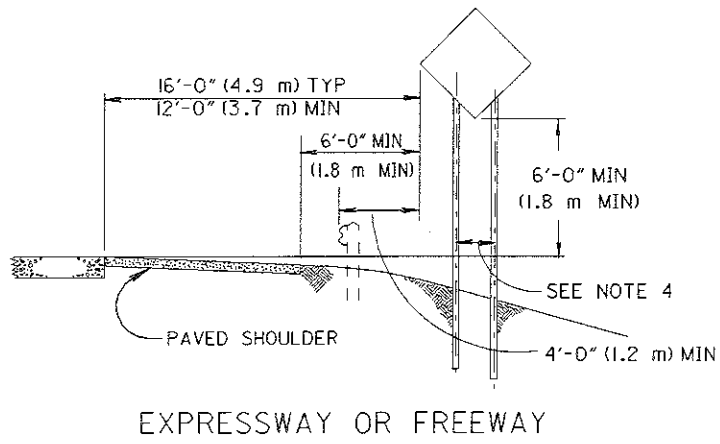

EXPRESSWAY OR FREEWAY

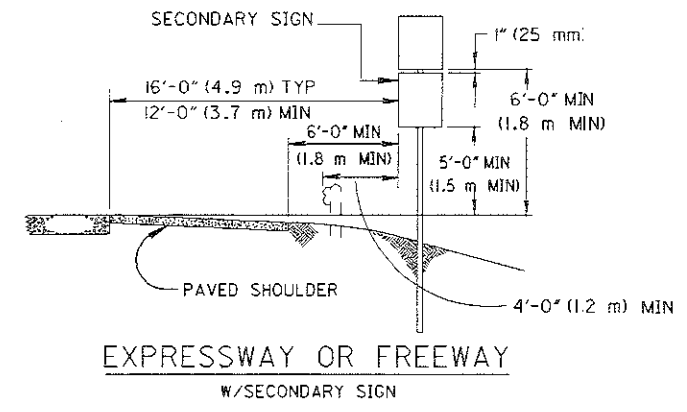

EXPRESSWAY OR FREEWAY
W/SECONDARY SIGN

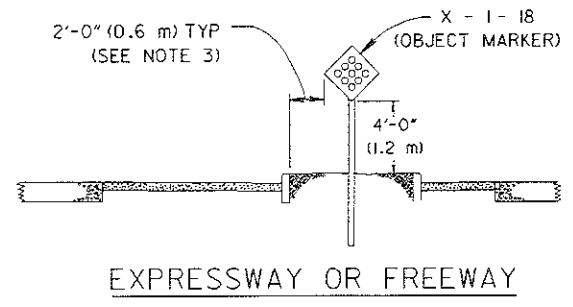

EXPRESSWAY OR FREEWAY

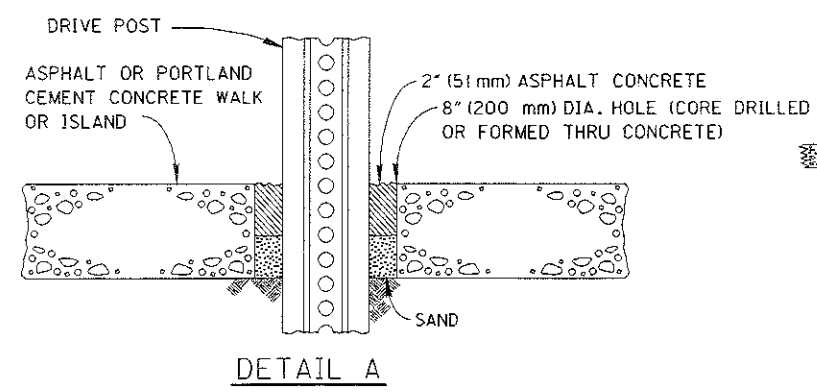

DETAIL A

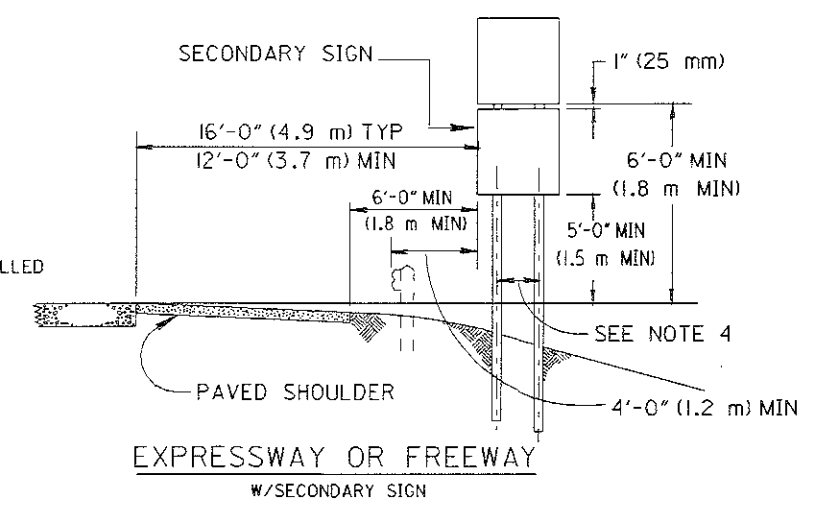

EXPRESSWAY OR FREEWAY
W/SECONDARY SIGN