

PAVEMENT MARKING SUB-SUMMARY

REFERENCE NO.	LOCATION	STATION		CENTER TURN LINES, ONE SOLID ONE DASHED EACH SIDE	24" STOP LINES	CROSSWALK LINES
		FROM	TO			
1	LLOYD ROAD				27	
2	LLOYD ROAD					200
3	LLOYD ROAD	10+50	21+30	.20		
4						

Ⓐ CURVE DATA
 RADIUS = 45.00'
 CENTER = N: 707932.89 E: 2248743.47
 P.C. = N: 707902.33 E: 2248776.50
 P.T. = N: 707944.52 E: 2248786.73

Ⓑ CURVE DATA
 RADIUS = 179.00'
 CENTER = N: 707909.74 E: 2248641.23
 P.C. = N: 707944.52 E: 2248786.73
 P.T. = N: 707982.97 E: 2248771.07

Ⓒ CURVE DATA
 RADIUS = 130.00'
 CENTER = N: 707923.48 E: 2248655.48
 P.C. = N: 707982.97 E: 2248771.07
 P.T. = N: 708027.76 E: 2248733.12

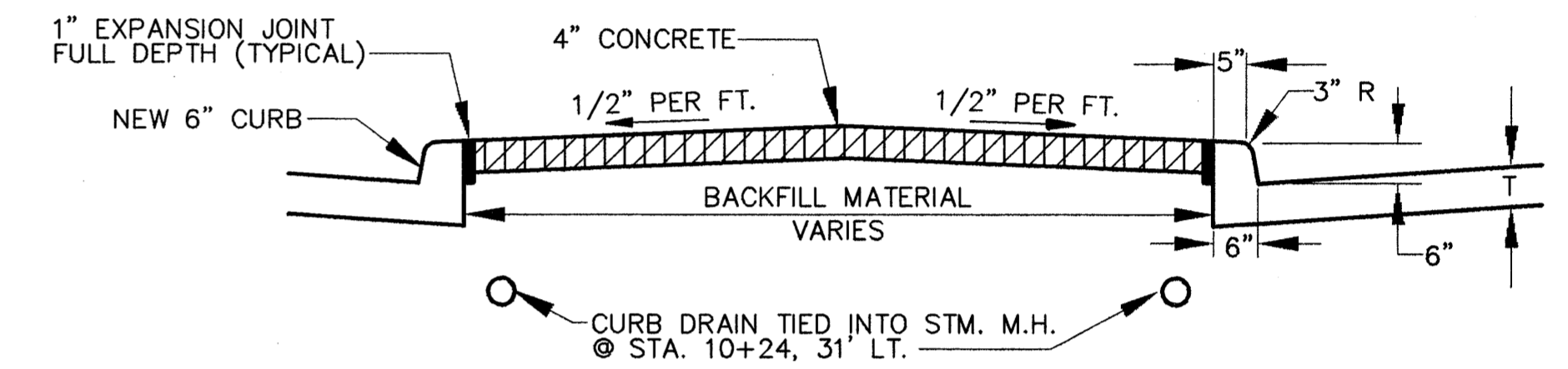

SECTION A-A

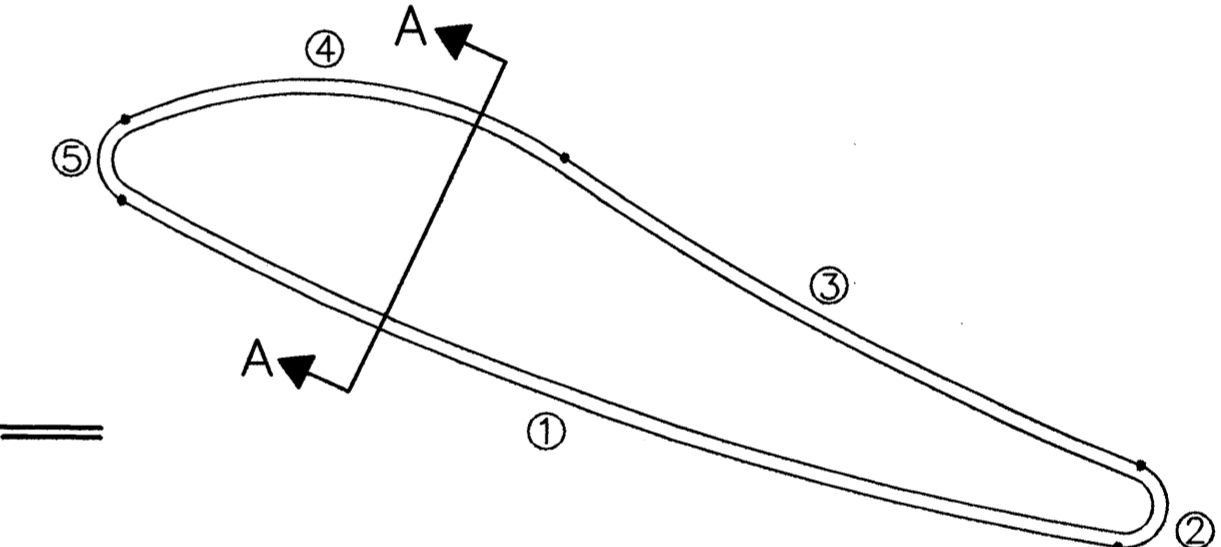

CONCRETE ISLAND DETAIL

- ① CURVE DATA
 RADIUS = 104.5'
 CENTER = N: 707915.90 E: 2248725.48
 P.C. = N: 707957.31 E: 2248821.43
 P.T. = N: 707987.98 E: 2248801.15
- ② CURVE DATA
 RADIUS = 1.50'
 CENTER = N: 707986.94 E: 2248800.06
 P.C. = N: 707987.98 E: 2248801.15
 P.T. = N: 707986.18 E: 2248798.78
- ③ CURVE DATA
 RADIUS = 100.50'
 CENTER = N: 707934.41 E: 2248712.63
 P.C. = N: 707986.18 E: 2248798.78
 P.T. = N: 707965.42 E: 2248808.23
- ④ CURVE DATA
 RADIUS = 15.50'
 CENTER = N: 707970.24 E: 2248822.95
 P.C. = N: 707965.42 E: 2248808.23
 P.T. = N: 707955.11 E: 2248819.61
- ⑤ CURVE DATA
 RADIUS = 1.60'
 CENTER = N: 707956.67 E: 2248819.96
 P.C. = N: 707955.11 E: 2248819.61
 P.T. = N: 707957.31 E: 2248821.43

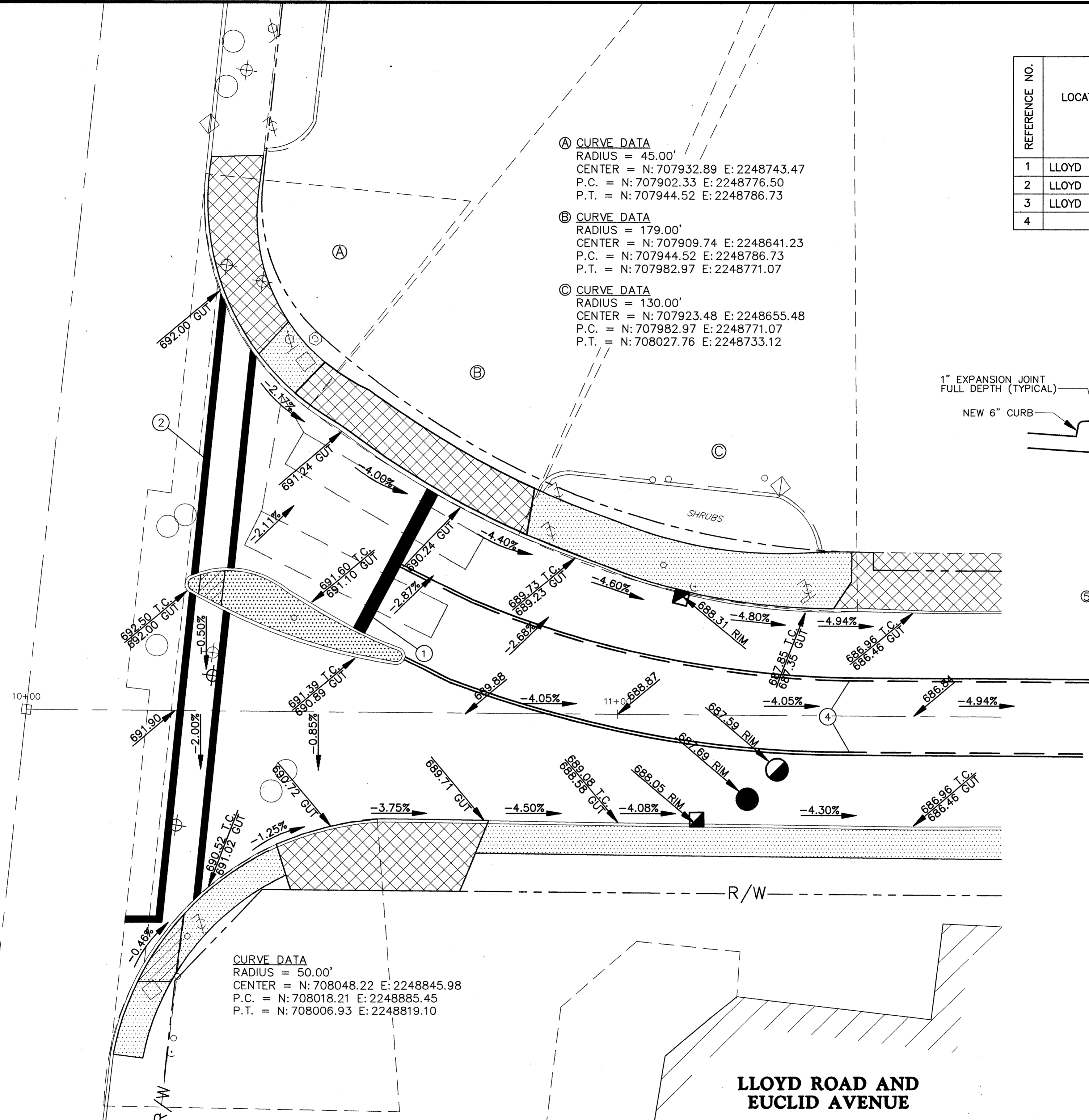

CURVE DATA
 RADIUS = 50.00'
 CENTER = N: 708048.22 E: 2248845.98
 P.C. = N: 708018.21 E: 2248885.45
 P.T. = N: 708006.93 E: 2248819.10

LLOYD ROAD AND EUCLID AVENUE

CT Consultants, Inc.
 Engineers • Architects • Planners
 Willoughby • Mentor • Columbus • North Canton • Youngstown



REV. NO.	DESCRIPTION	DATE	BY	CHK'D.

LLOYD ROAD IMPROVEMENTS
 CITY OF WICKLIFFE, LAKE COUNTY, OHIO

DATE: 2-14-00
DRAWN BY: M.F.L.
CHECKED BY: P.J.F.
APPROVED BY: D.W.
F.B. No. — PG. —

INTERSECTION / TRAFFIC DETAILS

SCALE 1"=10'	
CONTRACT No. 98367	
SHEET NO. 11	OF 20

COPYRIGHT - DATE: 02-14-00 13:13 CT CONSULTANTS INC. H:\98367\DWG\INTERSEC.DWG