

VIEW B-B
SHOWING FENCE CLOSURE PLATE PLAN

NOTES

Fencing stainless steel closure plates shall be installed for all post sections PS-1, PS-2 and PS-3. Stainless steel closure plates not required for post section PS-4 due to the bottom rail shown in the PS-4 detail. Any railing details without a bottom rail shall require the installation of the stainless steel closure plate.

- ① **DRIVE PINS** shall be 32 mm x 4 mm x 6 mm (Length x Shank Dia. x Head Dia.) flat head drive pins and washers, driven through closure plates into concrete. Steel shall be modified AISI 106X custom tempered to a hardness of 52-56 HRC and zinc plated in accordance with ASTM B633, SCl, Type III or ASTM B695. Powder actuated Fasteners shall be Hilti Fastening systems, ITW Ramset/Redhead or approved equal.
- ② **STAINLESS STEEL BENT CLOSURE PLATES**, 152 mm (with base plates BP-1 or BP-3) or 178 mm, (with base plates BP-2 or BP-4) shall be 3.40 mm ASTM A167, Type 304, mill finish.

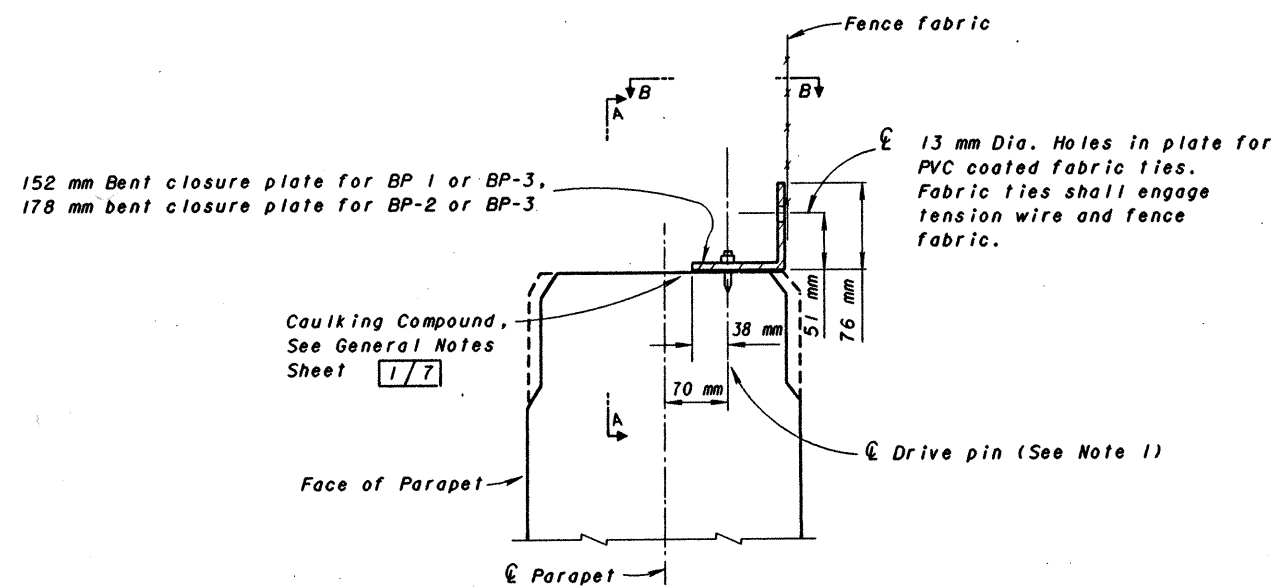

SECTION THRU PARAPET SHOWING
FENCE CLOSURE PLATE ELEVATION

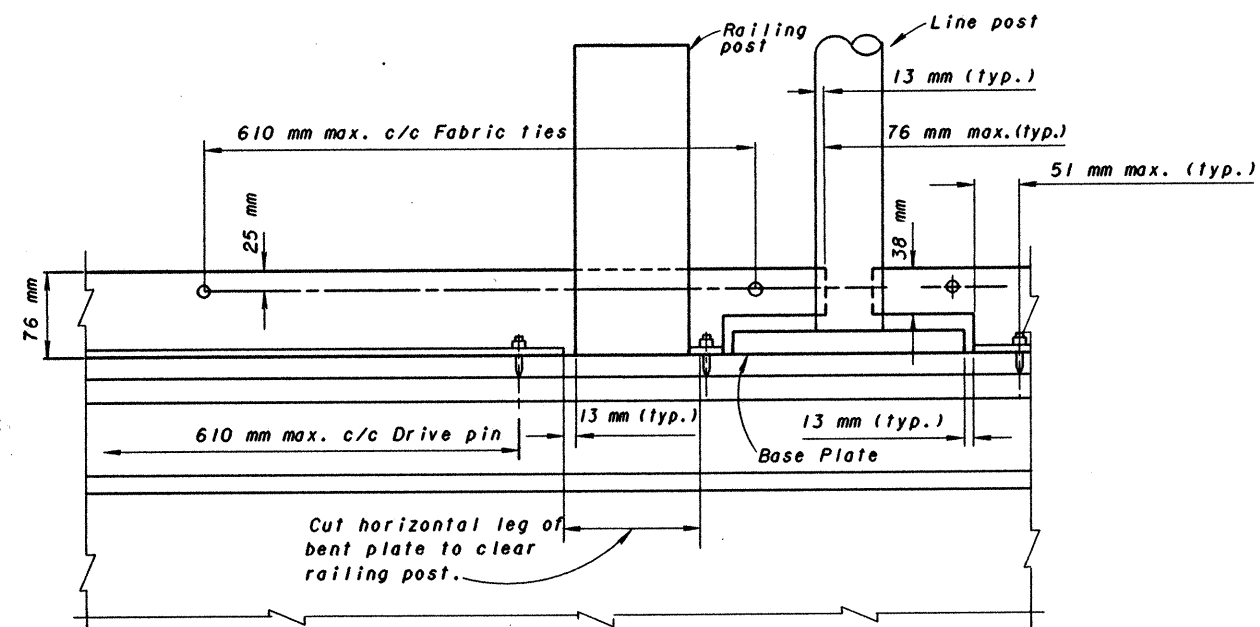

VIEW A-A

DESIGN AGENCY
BUREAU OF BRIDGES
AND STRUCTURAL DESIGN

STATE OF OHIO DEPARTMENT OF TRANSPORTATION
Richard L. Engel
ENGINEER OF BRIDGES
5-20-95
DATE

REVIEWED	WTF/LMW
CHECKED	RLD
PREPARED	JCR
REVISIONS	GFJ/RJS
DRAWING NO.	VPF-1-90M

STANDARD DRAWING
VANDAL PROTECTION FENCE
FENCE CLOSURE PLATE DETAILS