

NOTES

- 1/2" (13 mm) preformed joint filler as per 705.03 shall be used between foundations and adjacent paved areas.
- The size, number and orientation of conduit ells shall be as shown in the plan, except that on 3/4" (19 mm) EMT shall be installed in each foundation.
- The size, number and location of anchor bolts shall be in accordance with the manufacturer's recommendations.
- All pedestals shall be provided with a method of securely attaching a No. 4 AWG insulated copper grounding cable to the pedestal or anchor bolt. No cables or connections shall be external to the pedestal.
- The pedestal shaft length as shown in the plans includes the pedestal base height for either base design.
- The pedestal base shall set on the foundation top without grouting, preformed fillers or leveling nuts under the base. Steelshims may be used under the base for leveling the installation.
- The foundation area of contact with the pedestal base shall be level. If adjacent paved areas slope, the remainder of the foundation top shall be beveled to meet the adjacent elevations.
- A cast steel anchor base of equivalent strength may be used in lieu of the plate base.
- A 40" x 30" x 4" (1.0 m x 0.8 m x 100 mm) work pad shall be located in front of each pedestal mounted controller cabinet unless in an otherwise paved area. The work pad for the ground mounted controller shall be sized as shown in the table. When required, this item shall be paid for under Item 633 Controller Work Pad. In level areas the top of the pad shall be 1" (25 mm) above the ground line. In steeply sloped areas the pad's location shall be adjusted to provide access and drainage.
- Ground mounted controller cabinets shall be sealed to the foundation with a flexible weatherproof caulking compound.

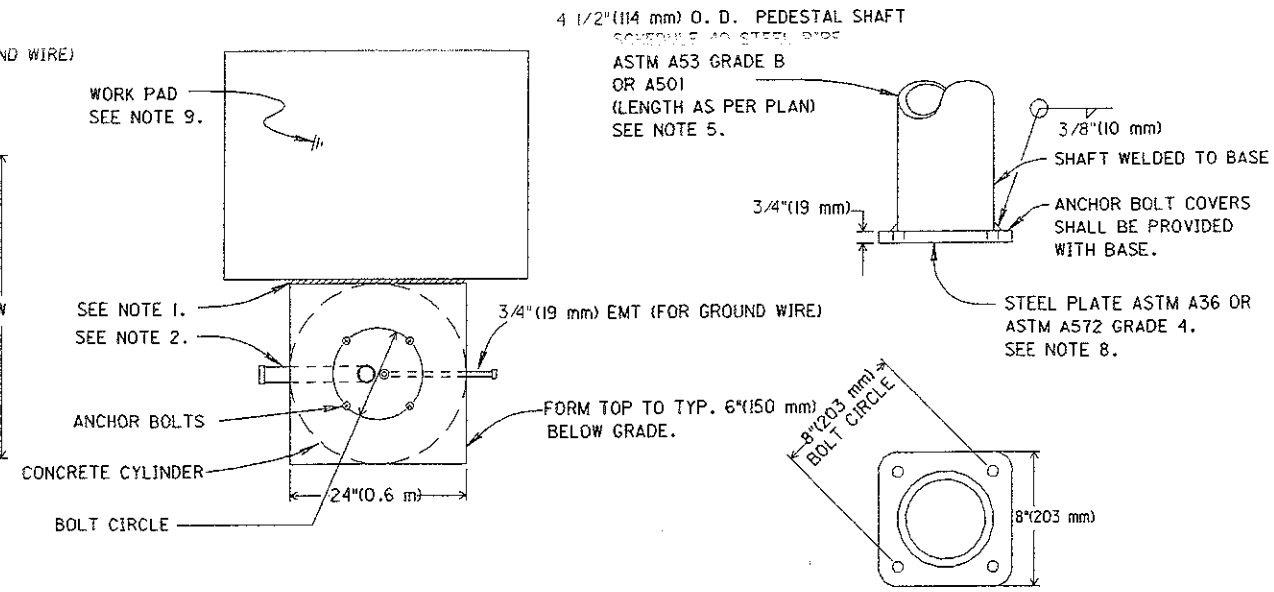
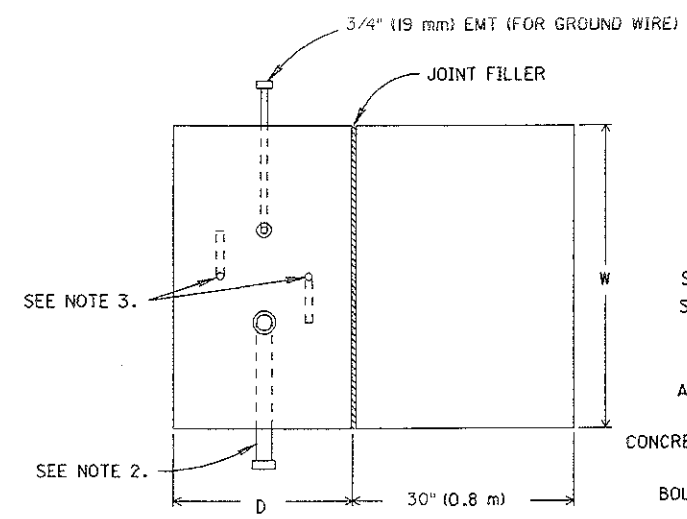
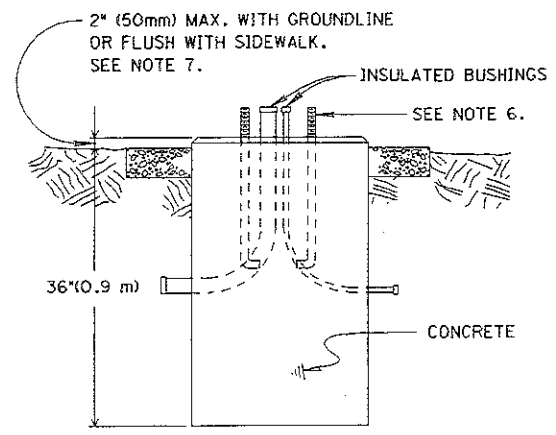
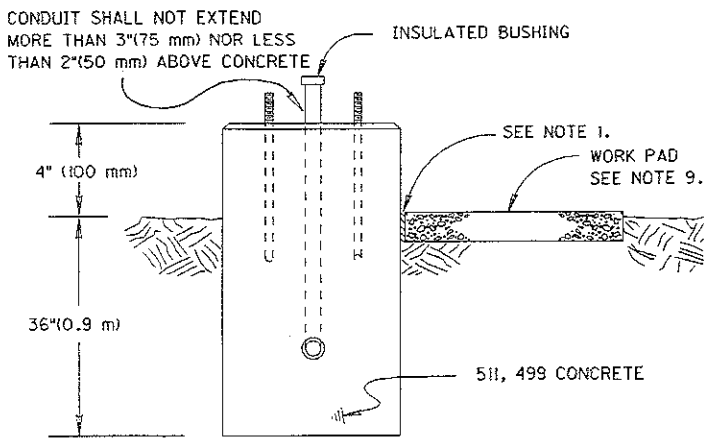
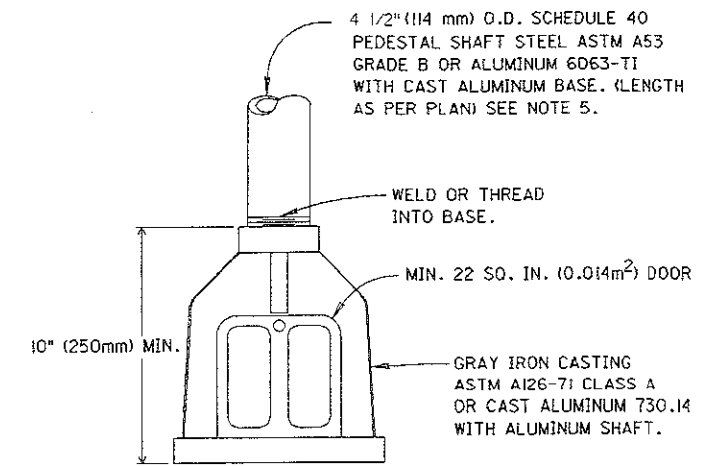

PLATE PEDESTAL BASE



PEDESTAL FOUNDATION



TRANSFORMER TYPE PEDESTAL BASE

TYPE	W	D	FOUNDATION CONCRETE	WORK PAD
1	40" (1.0 m)	24" (0.6 m)	.99 C.Y. (0.72 m ³)	0.96 S.Y. (0.80 m ²)
2	50" (1.3 m)	36" (0.9 m)	1.85 C.Y. (1.40 m ³)	1.24 S.Y. (1.04 m ²)

GROUND MOUNTED CONTROLLER FOUNDATION

FOUNDATION CONCRETE	WORK PAD
0.42 C.Y. (0.32m ³)	0.96 C.Y. (0.80m ²)

PEDESTAL ANCHOR BOLT ASTM A307 STEEL

