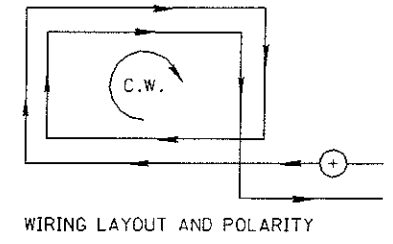
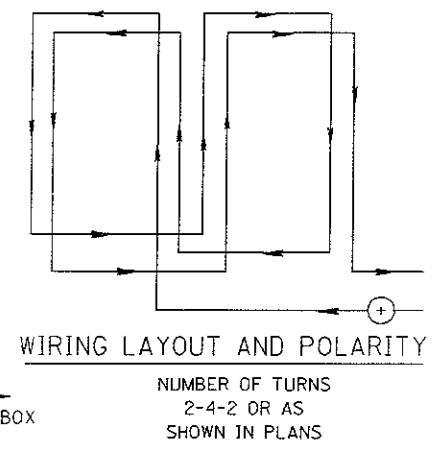
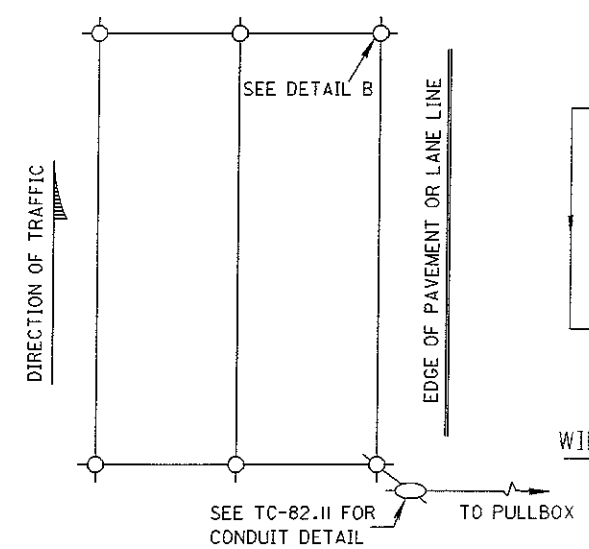


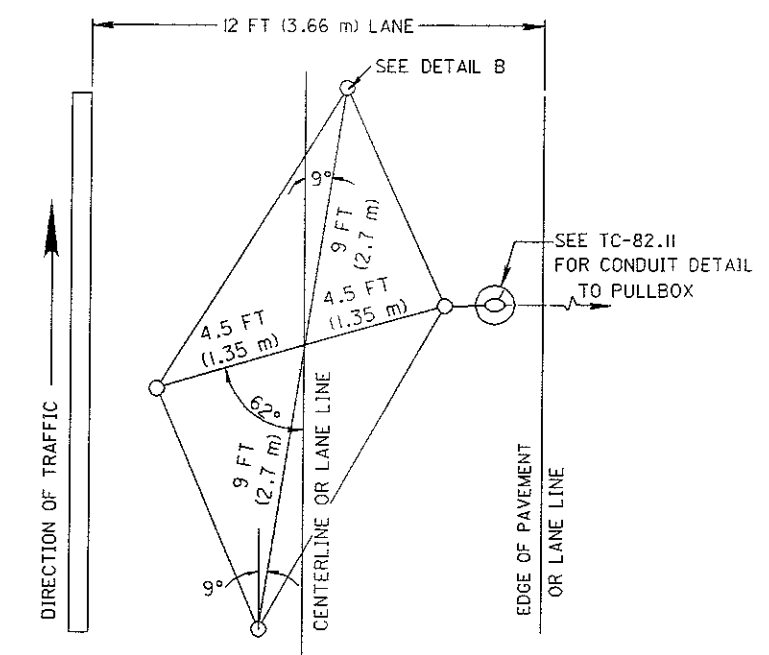
| LOOP CONSTRUCTION             |                 |
|-------------------------------|-----------------|
| LOOP PERIMETER                | NUMBER OF TURNS |
| LESS THAN 40 FT (12 m)        | 4               |
| 40 FT (12 m) TO 160 FT (49 m) | 3               |
| OVER 160 FT (49 m)            | 2               |



**TYPICAL DETECTOR LOOP DETAILS**

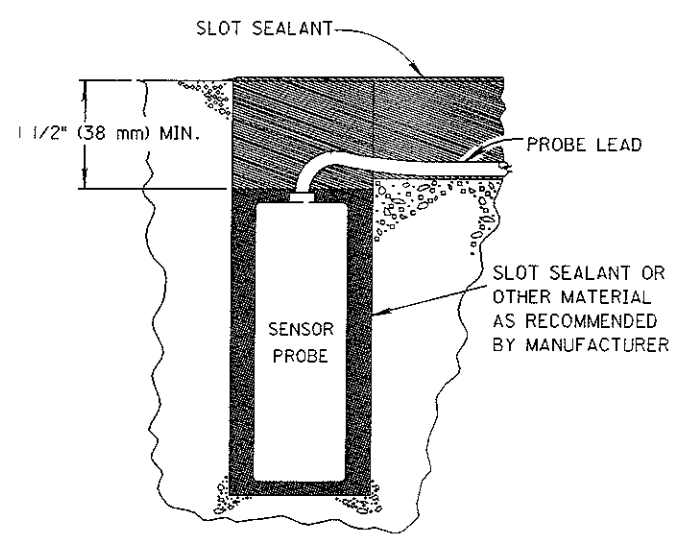


**FIGURE 8 (QUADRUPOLE) LOOP DETAILS**



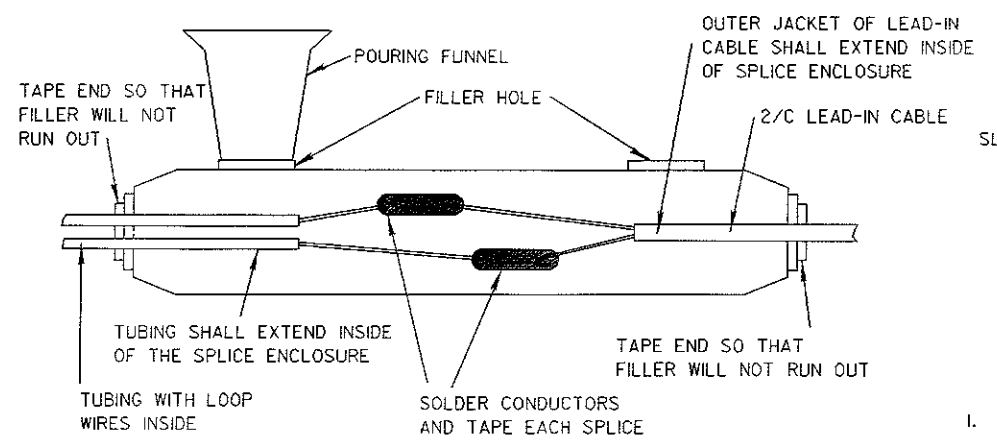
OTHER SIZES CAN BE DESIGNATED AS LONG AS THE ANGLES REMAIN THE SAME AS SHOWN AND THE DIMENSION RATIO REMAINS 2:1.

**ANGULAR DESIGN DETECTION LOOP DETAIL**



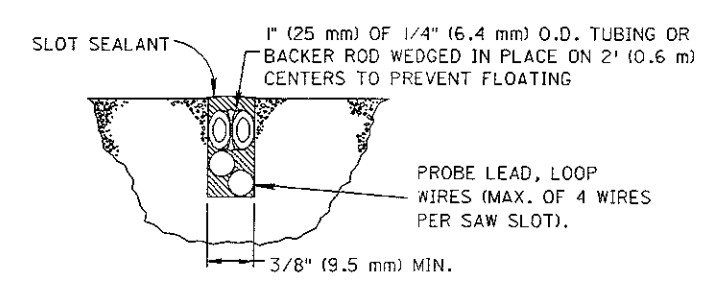
THE MAGNETOMETER HOLE SIZE SHALL BE APPROXIMATELY 3/4" (19 mm) LARGER THAN THE DETECTOR PROBE DIAMETER AND A DEPTH AS RECOMMENDED BY THE MANUFACTURER OR AS DIRECTED BY THE ENGINEER.

**MAGNETOMETER SENSOR PROBE DETAIL**



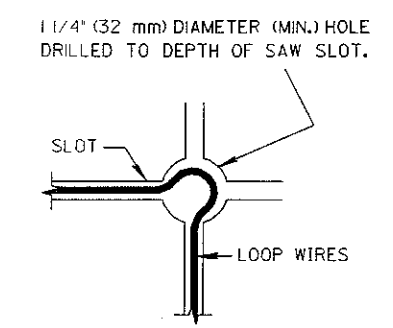
1. LOOP DETECTOR WIRE TO LEAD-IN CABLE SPLICES WITHIN THE ENCAPSULATED SPLICE ENCLOSURE SHALL BE SOLDERED.
2. IF A PULLBOX IS NOT SPECIFIED IN THE PLANS, THE WATERPROOF SPLICE ENCLOSURE SHALL BE LOCATED IN THE FIRST ENTERED POLE OR PEDESTAL, EXCEPT IF THE CONTROLLER CABINET IS MOUNTED ON THAT POLE OR PEDESTAL, IN WHICH CASE THE LOOP WIRES SHALL BE ROUTED DIRECTLY INTO THE CABINET.
3. VISIBLE AIR BUBBLES (VOIDS) OF 1/4" (6 mm) OR GREATER MAY BE CAUSE FOR REJECTION OF THE SPLICE.

**SPLICE ENCLOSURE DETAIL**



1. MINIMUM SAW SLOT DEPTH: ASPHALT 4" (100 mm), CONCRETE 2" (50 mm)
2. LOOP DETECTOR WIRE IN TUBING SHALL BE AS SPECIFIED IN CMS TABLE 732.19.
3. LOOP DETECTOR SEALANT SHALL BE A PREQUALIFIED PRODUCT IN ACCORDANCE WITH SUPPLEMENT 1048.
4. SAW SLOTS AND PROBE HOLES SHALL BE THOROUGHLY CLEANED AND DRIED PRIOR TO INSTALLATION OF SEALANT.
5. WIRE INSTALLATIONS IN NEW ASPHALT MAY BE SAWS AND EMBEDDED WITH SEALANT IN A SUB-SURFACE COURSE WITH SUBSEQUENT COVERING BY THE SURFACE COURSE, SUBJECT TO APPROVAL OF THE ENGINEER.

**SLOT DETAIL**



**DETAIL B**