

### NOTES

1. Sign brackets shall be a 4" x 3" x 1/4" (102 mm X 76 mm x 6.4 mm) aluminum zee at 2.85 LB/FT (4.23 kg/m).
2. Provide intermediate sign brackets if the sign extends more than 4 feet (1.2 m) above or below an attachment point.
3. U-Bolts, other bolts, nuts and washers shall be stainless steel for use with aluminum chords. When used with galvanized sign structures the U-Bolts only may be galvanized steel.
4. Prevent contact between aluminum and galvanized parts with a minimum 1/16" (1.6 mm) thick chloroprene gasket or approved equal.
5. Type A shall be for supports where the sign height is less than 1 foot (0.3 m) greater than the attachment point spacing.
6. Type B shall be for back to back mounted signs.
7. Detail C - fixture support arm mounting for mercury vapor lighted signs complying with TC-31.21.
8. Attach gusset plates by bolting or welding.

ATTACHMENT POINT SPACING		
SUPPORT TYPE	DESIGN	S
7.2	1	2'-4"
	2	3'
	3	4'
7.3	1 & 2	3'
	3 & 4	4'
7.4	1	3'
7.5	2 & 3	4'
7.6	4	5'
7.65	6 & 6 ALT.	3'
	8 & 8 ALT.	5'
9.12	SINGLE ARM	
9.24	1 THRU 4	4'
10.48	1 THRU 5	4'
	6 THRU 8	6'
11.08	SINGLE ARM	
12.24	1 THRU 4	4'
	5 THRU 8	6'
12.30	1 THRU 4 ALT.	4'
	5 THRU 12 ALT.	6'
15.8	ALL	3'
15.115	ALL	5'
16.10	SINGLE ARM	

ATTACHMENT POINT SPACING		
SUPPORT TYPE	DESIGN	S (meter)
7.2	1	0.7
	2	0.9
	3	1.2
7.3	1 & 2	0.9
	3 & 4	1.2
7.4	1	0.9
7.5	2 & 3	1.2
7.6	4	1.5
7.65	6 & 6 ALT.	0.9
	8 & 8 ALT.	1.5
9.12	SINGLE ARM	
9.24	1 THRU 4	1.2
10.48	1 THRU 5	1.2
	6 THRU 8	1.8
11.08	SINGLE ARM	
12.24	1 THRU 4	1.2
	5 THRU 8	1.8
12.30	1 THRU 4 ALT.	1.2
	5 THRU 12 ALT.	1.8
15.8	ALL	0.9
15.115	ALL	1.5
16.10	SINGLE ARM	

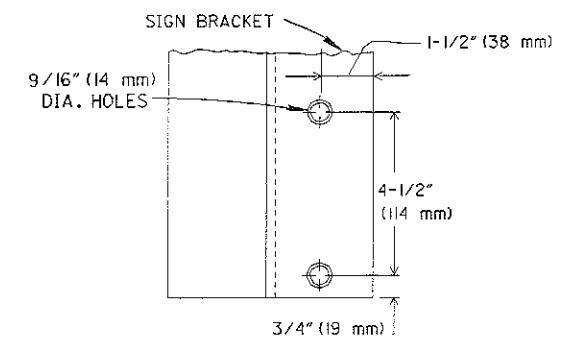
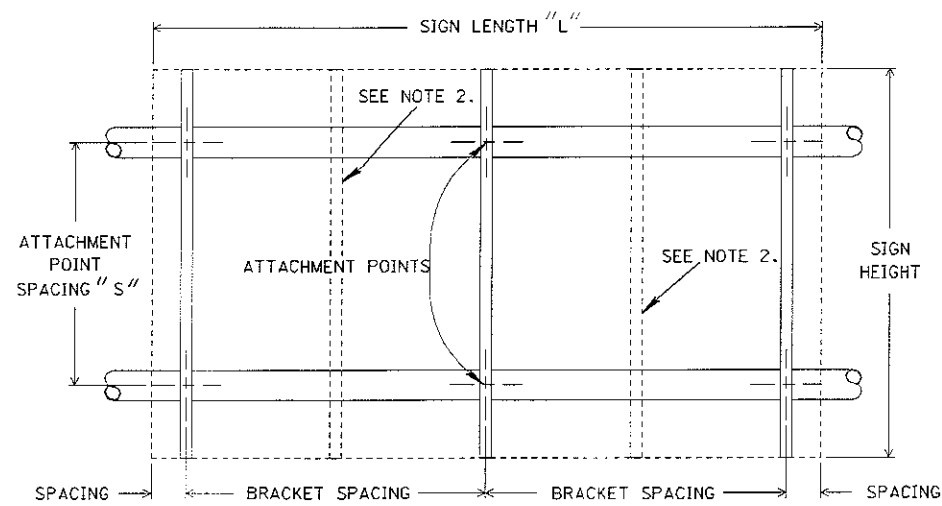

**DETAIL C**  
(SEE NOTE 7)