

NOTES

- PAYMENT FOR PROTECTION OF DUCT-CABLE AND DISTRIBUTION CABLE UNDER GUARDRAIL, AS DETAILED IN METHODS 1 THRU 4, SHALL BE INCLUDED IN THE UNIT PRICES BID FOR THE AFFECTED CABLE AND TRENCH ITEMS.

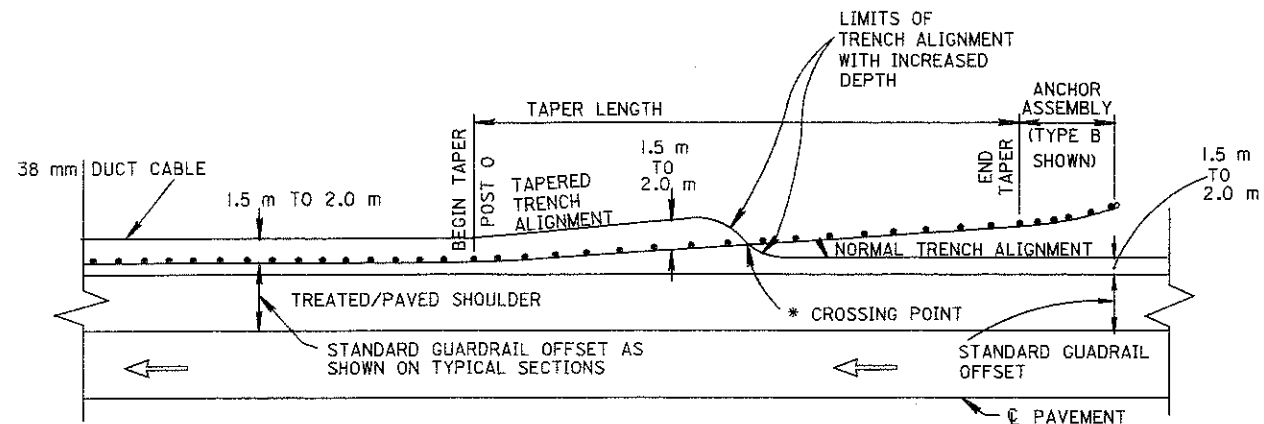

* CHOOSE CROSSING POINT SUCH THAT GUARDRAIL POST ALIGNMENT IS APPROXIMATELY MIDWAY BETWEEN TAPERED TRENCH ALIGNMENT AND NORMAL TRENCH ALIGNMENT

TRENCH LOCATION AT TAPERED OR WIDE FLARE GUARDRAIL ALIGNMENT

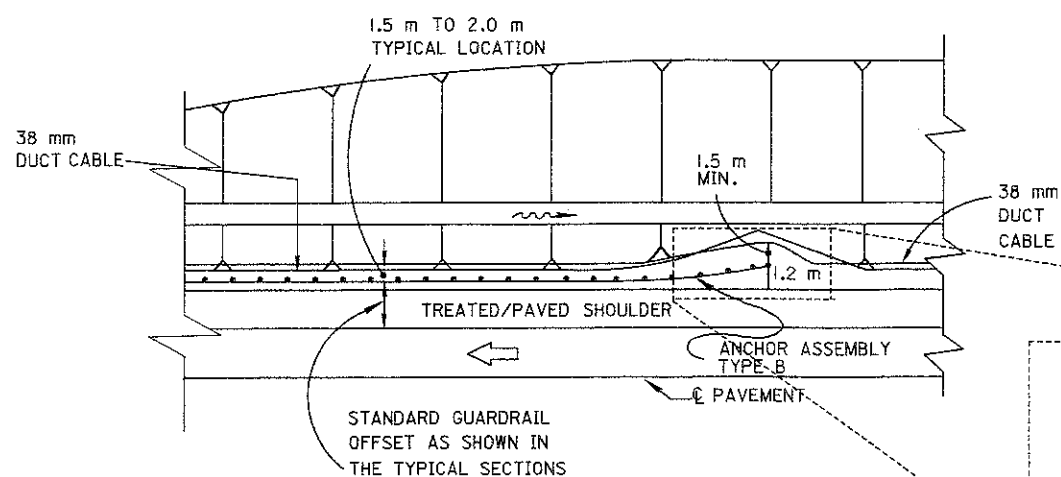

TRENCH LOCATION AT 1.2 m - FLARE GUARDRAIL ALIGNMENT

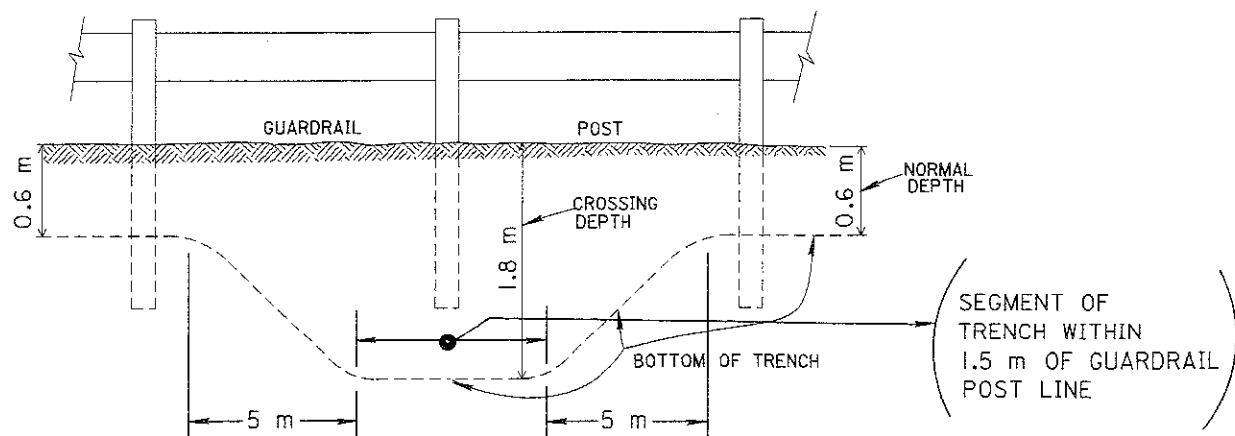
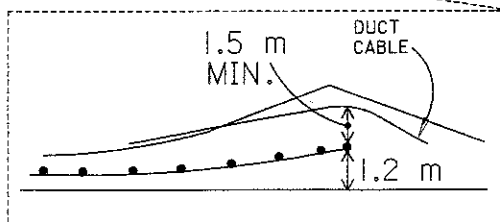

METHOD FOR PROTECTING DUCT-CABLE UNDER GUARDRAIL

INCREASED DEPTH OF CABLE TRENCH AT POINT OF CROSSING TO BE USED WHEN CIRCUIT IS INSTALLED PRIOR TO GUARDRAIL INSTALLATION

METHODS OF PROTECTING DUCT-CABLE

(SEE NOTE 1)

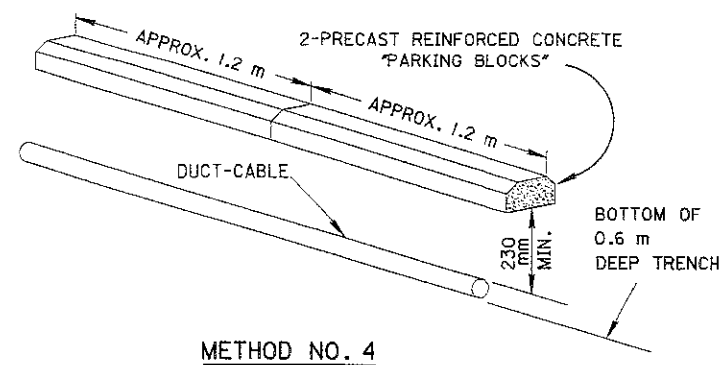
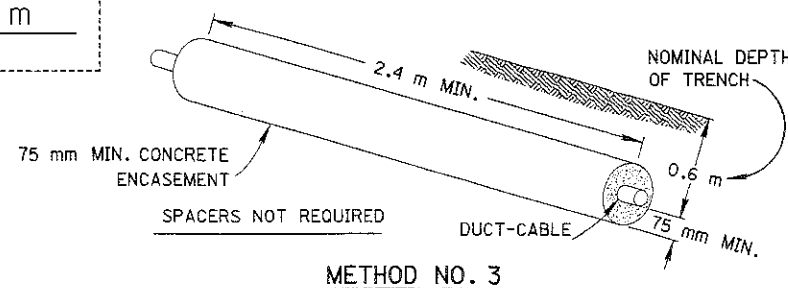
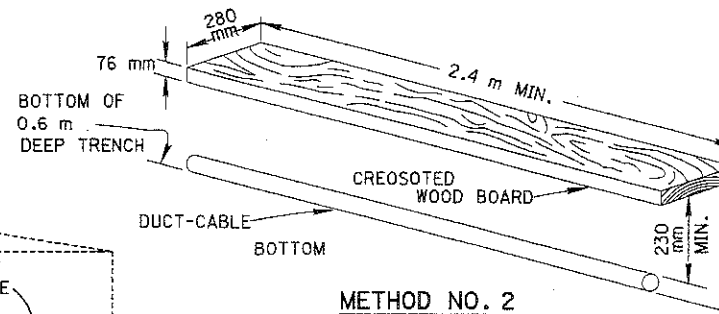
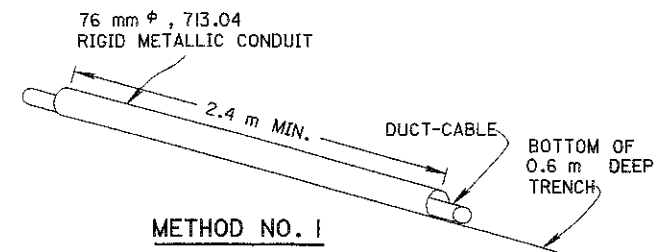

OFFICE OF TRAFFIC ENGINEERING DIVISION OF ENGINEERING POLICY OHIO DEPARTMENT OF TRANSPORTATION	
HIGHWAY LIGHTING	DATE 05/01/95
ROADWAY CONDUIT DETAILS I	
STANDARD CONSTRUCTION DRAWING	HL-30.2IM
APPROVED <i>[Signature]</i>	ADMINISTRATOR