

See Sht. 3/3 for SECTION A-A
PERPENDICULAR CURB RAMP DETAIL

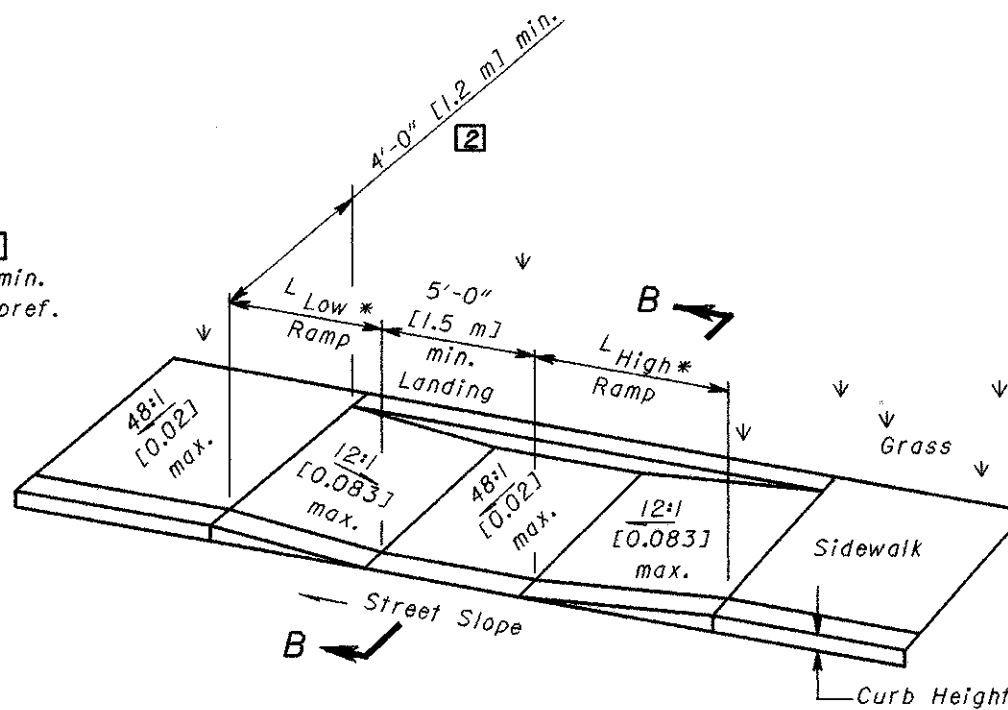

See Sht. 3/3 for SECTION B-B
PARALLEL CURB RAMP DETAIL (DOUBLE)

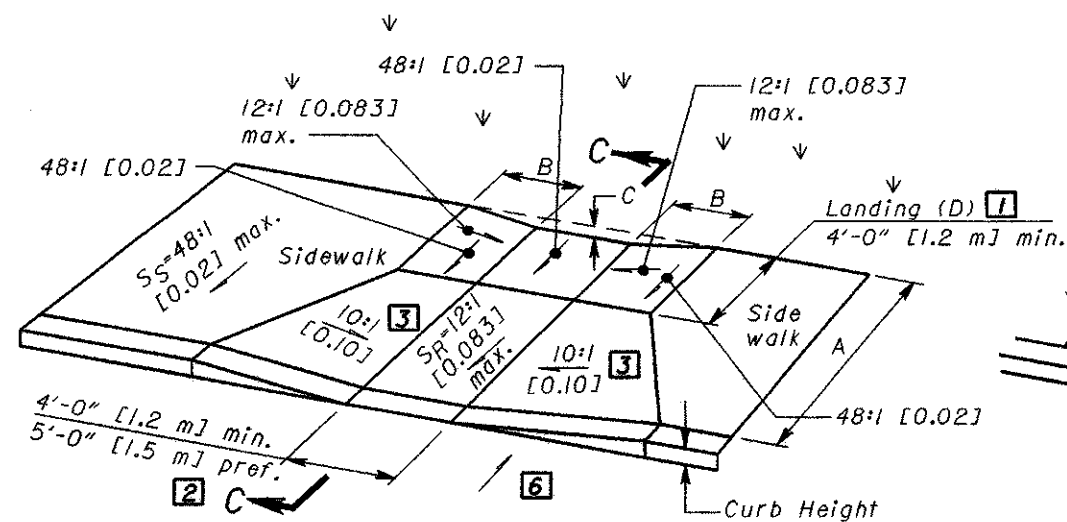

See Sht. 3/3 for SECTION C-C
COMBINED CURB RAMP DETAIL

$$B = C / 0.083$$

$$C = [Curb\ ht. + A(S_S)] - [(A-D)S_R + D(0.02)]$$

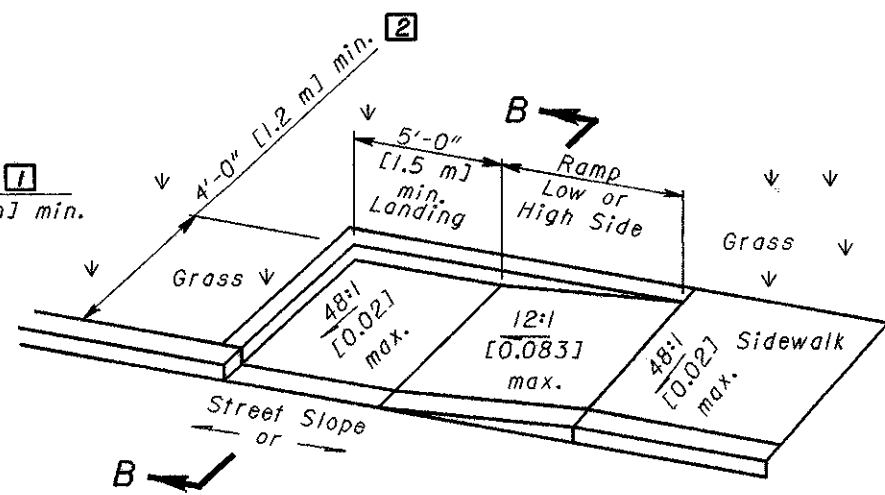

See Sht. 3/3 for SECTION B-B
PARALLEL CURB RAMP DETAIL (SINGLE)

Street Slope	Ramp Length @ 1"/ft [0.083]	
	LOW SIDE*	HIGH SIDE*
0.01	5'-5" [1.6 m]	6'-10" [2.1 m]
0.02	4'-10" [1.5 m]	7'-11" [2.4 m]
0.03	4'-5" [1.3 m]	9'-5" [2.9 m]
0.04	4'-1" [1.2 m]	11'-8" [3.6 m]
0.05	3'-9" [1.1 m]	15'-2" [4.6 m]

* Measured along the back of a 6" [150] high curb.

$$L_{HIGH} = \frac{Curb\ ht.}{0.083 - Street\ Slope}$$

$$L_{LOW} = \frac{Curb\ ht.}{0.083 + Street\ Slope}$$

LEGEND

- 1 May be reduced to 3'-0" [915] in existing sidewalks if the landing is unconstrained along the back edge.
- 2 May be reduced to 3'-4" [1.02 m] in existing sidewalks to better fit the walk configuration or where site conditions are restricted by narrow walks, pole foundations, drainage inlets, etc. The width may be tapered.
- 3 Where landing width (D) has been reduced to 3'-0" [915] the flared sides shall have a maximum slope of 12:1 [0.083].
 Flared sides are not required where the edges of a curb ramp are protected by landscaping or other barriers to travel by wheel chair users or pedestrians across the edge of the curb ramp. However, if the flared sides are used in these areas, they may be of any slope.
- 4 The slope of the ramp toward the curb is preferred to be 12:1 [0.083] or flatter related to the horizontal, but the maximum slope shall be 12:1 [0.083] relative to the existing or proposed walk slope.
 In existing sidewalks, where the maximum ramp slope (S_R) is not feasible, it may be reduced as follows:
 A) 10:1 [0.10] for a max. rise of 6" [150],
 B) 8:1 [0.125] for a max. rise of 3" [75],
 C) 6:1 [0.167] over a max. run of 2'-0" [610] for historic areas where a flatter slope is not feasible.
- 5 The minimum length of a perpendicular ramp is 6' [2.0 m] from the back of a 6" [150] curb and may be increased where feasible to obtain a flatter ramp slope or to better blend with the walk configuration.
- 6 Gutter counter slopes at the foot of perpendicular curb ramps should not exceed 20:1 [0.05] over a distance of 2'-0" [610] from the curb.
- 7 Dimensions derived by equation are nominal. Construct ramps to meet required slopes and existing conditions.

THIS DRAWING REPLACES BP-7.1M DATED 10-28-94.

OHIO DEPARTMENT OF TRANSPORTATION
 ROADWAY ENGINEERING SERVICES
 STANDARD ROADWAY CONSTRUCTION DRAWING
 CURB RAMPS
 NUMBER BP-7.1
 1/3

REVISIONS
 STDS. ENGR. M. EVANS
 DRAWN D. FOCKE

DATE 7-28-00
 ROADWAY DESIGN ENGINEER