

NOTES

- ELASTOMERIC BEARINGS SHALL COMPLY WITH ITEM 516 AND AASHTO STANDARD SPECIFICATION FOR HIGHWAY BRIDGES, SECTION 18, BEARING DEVICES, DIVISION II, CONSTRUCTION, ARTICLES 18.4.5.1 AND 18.5.6.2. BEARINGS SHALL BE GRADE 3, 50 DUROMETER ELASTOMER, AND SHALL BE SUBJECTED TO THE LOAD TESTING REQUIREMENTS DEFINED IN ARTICLE 18.7.4.5 OF THE AASHTO DOCUMENT LISTED ABOVE. BEARINGS WERE DESIGNED UNDER SECTION 14.6.6 OF SECTION 14, BEARINGS, DIVISION I, DESIGN. TESTING SHALL BE INCLUDED IN THE UNIT PRICE BID FOR THE BEARINGS, EACH.
- WELDING SHALL BE CONTROLLED SO THAT THE PLATE TEMPERATURE AT THE ELASTOMER BONDED SURFACE DOES NOT EXCEED 300° F AS DETERMINED BY USE OF PYROMETRIC STICKS OR OTHER TEMPERATURE MONITORING DEVICES.
- BEARING REPOSITIONING: IF THE STEEL IS ERECTED AT AN AMBIENT TEMPERATURE HIGHER THAN 80° F OR LOWER THAN 40° F AND THE BEARING SHEAR DEFLECTION EXCEEDS 1/6 OF THE BEARING HEIGHT AT 60° F (±) 10° F, THE BEAMS OR GIRDERS SHALL BE RAISED TO ALLOW THE BEARINGS TO RETURN TO THEIR UNDEFORMED SHAPE AT 60° F (±) 10° F.
- THE STEEL LOAD PLATE SHALL BE ASTM A572/A709 GRADE 50 STEEL. THE PLATE SHALL BE SHOP PAINTED WITH SYSTEM IZEU IN ACCORDANCE WITH ITEM 514.
- THE STEEL LOAD PLATE SHALL BE BONDED BY VULCANIZATION TO THE ELASTOMER DURING THE MOLDING PROCESS.
- TOTAL DESIGN LOAD FOR BEARINGS EQUALS THE SUM OF THE DEAD LOADS AND LIVE LOADS TABULATED IN THE BEARING TABLE.
- BEARING ANCHOR RODS: AT THE OPTION OF THE CONTRACTOR, THE BEARING ANCHOR RODS (OR FORMED HOLES), LOCATED AND SUPPORTED BY TEMPLATES, MAY BE CAST-IN-PLACE. IF ANCHOR RODS ARE NOT CAST-IN-PLACE THEY SHALL BE GROUTED IN ACCORDANCE WITH ITEM 510 USING NONSHRINK, NONMETALLIC GROUT MEETING THE REQUIREMENTS OF 705.20.
- ANCHOR RODS SHALL BE GALVANIZED AS PER O.D.O.T. CONSTRUCTION AND MATERIAL SPECIFICATION 711.02. ANCHOR RODS SHALL EXTEND 1 INCH ABOVE THE LOAD PLATE (SEE DETAIL).
- BASIS OF PAYMENT: THE UNIT BID PRICE SHALL INCLUDE ALL MATERIALS, LABOR, AND INCIDENTALS NECESSARY TO FURNISH AND INSTALL LAMINATED ELASTOMERIC BEARINGS. SAMPLE BEARINGS SHALL NOT BE MEASURED FOR PAYMENT. PAINTING OF STEEL PLATES SHALL BE INCIDENTAL TO THE COST OF ITEM 516, ELASTOMERIC BEARING WITH INTERNAL LAMINATES AND LOAD PLATE (NEOPRENE).

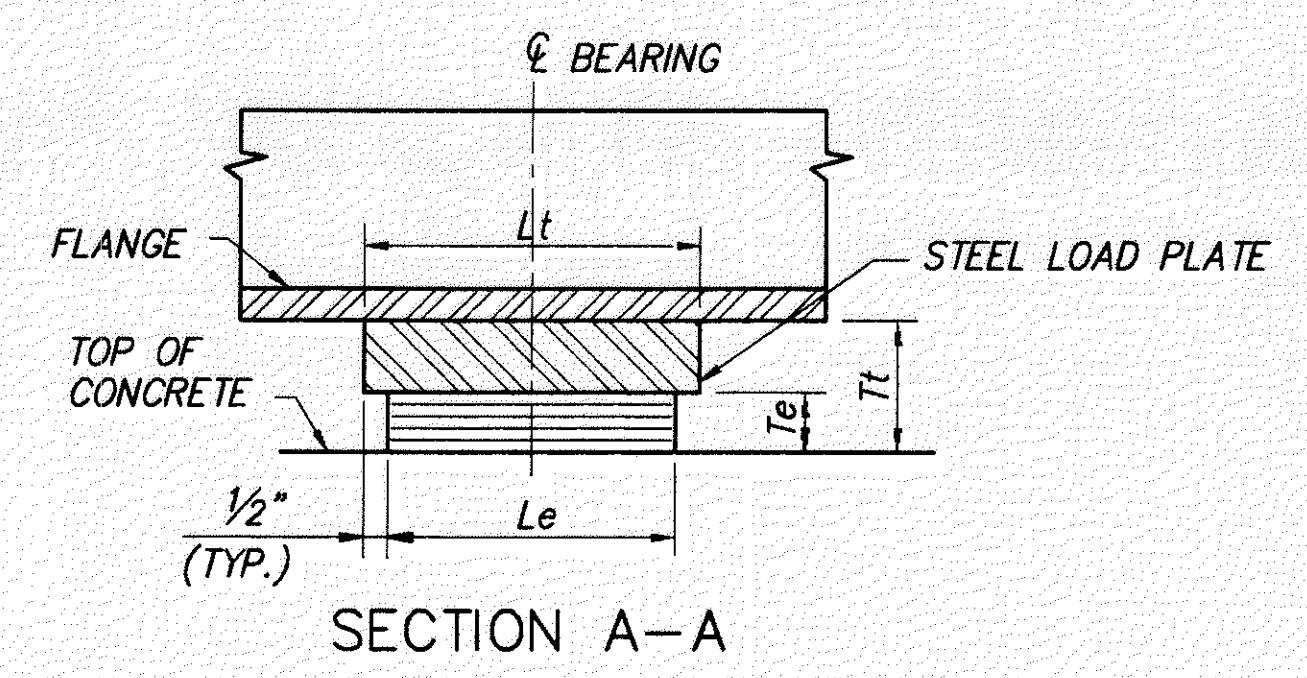

LAMINATED ELASTOMERIC EXPANSION BEARING AT REAR ABUTMENT

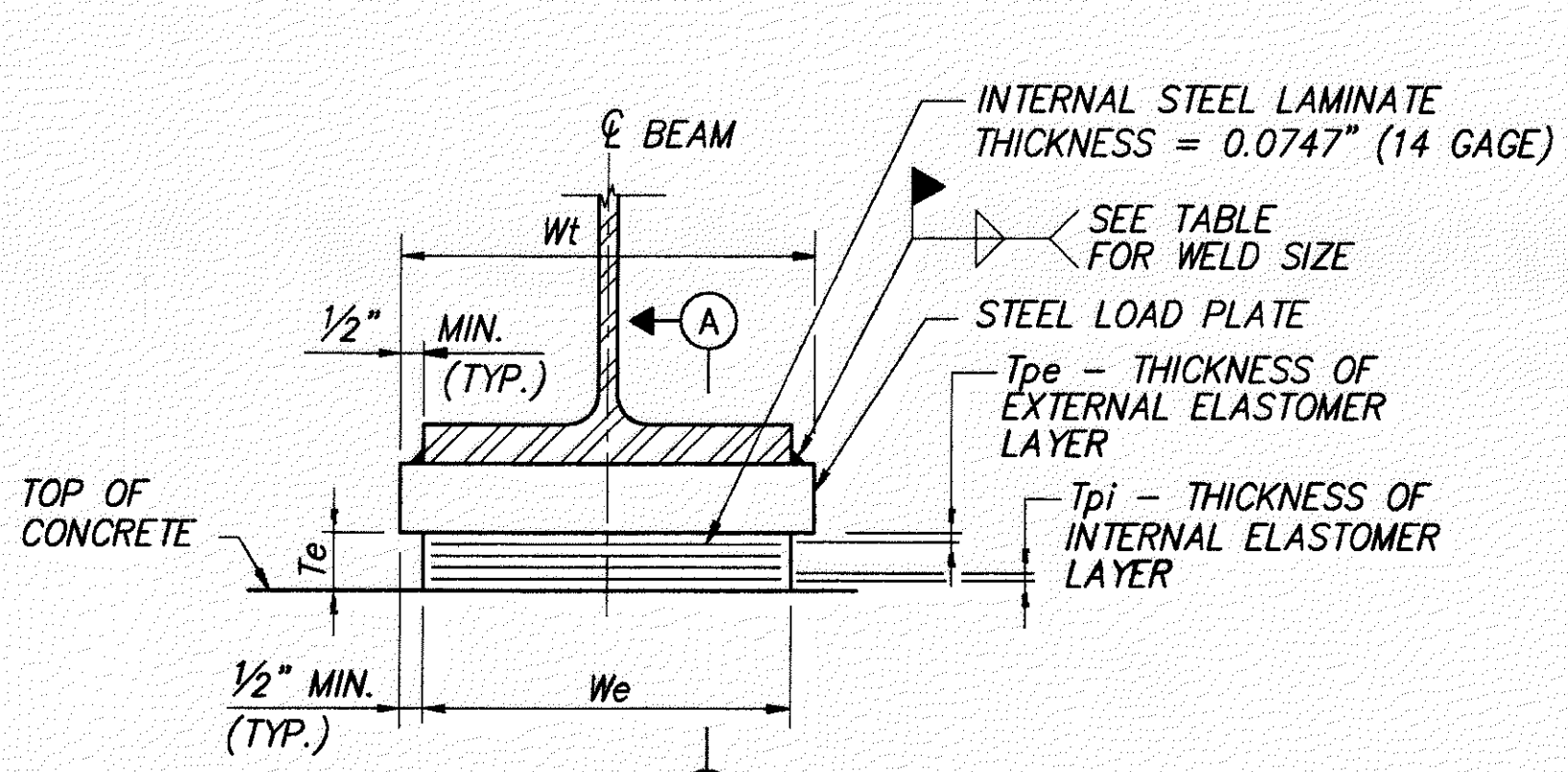
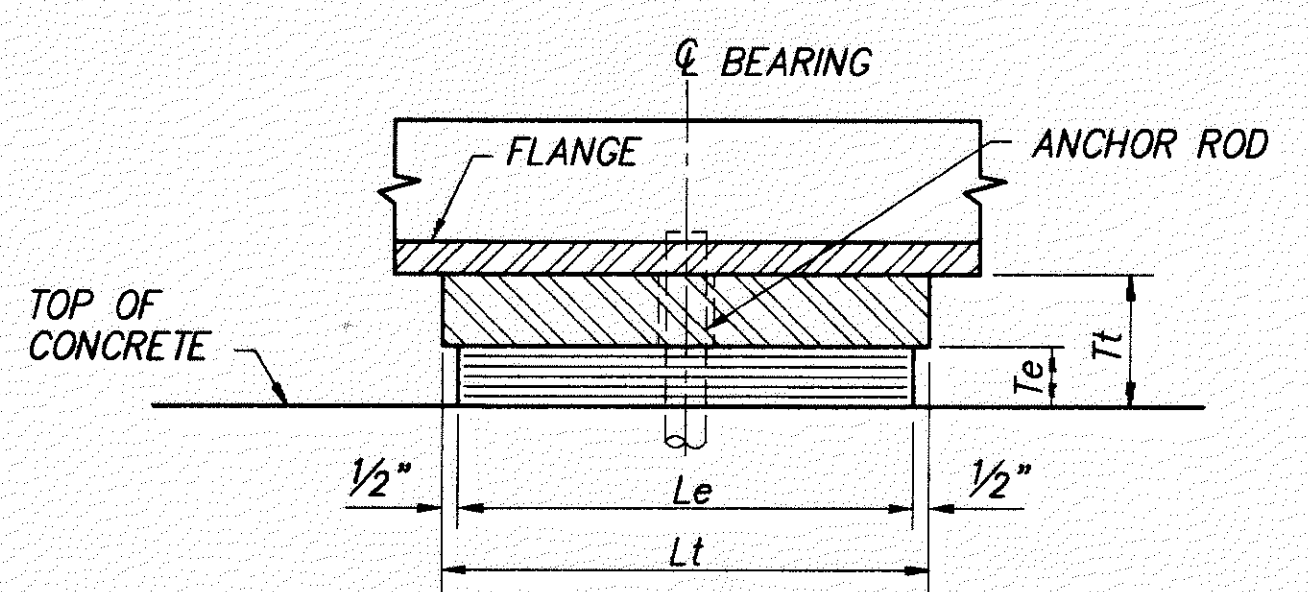
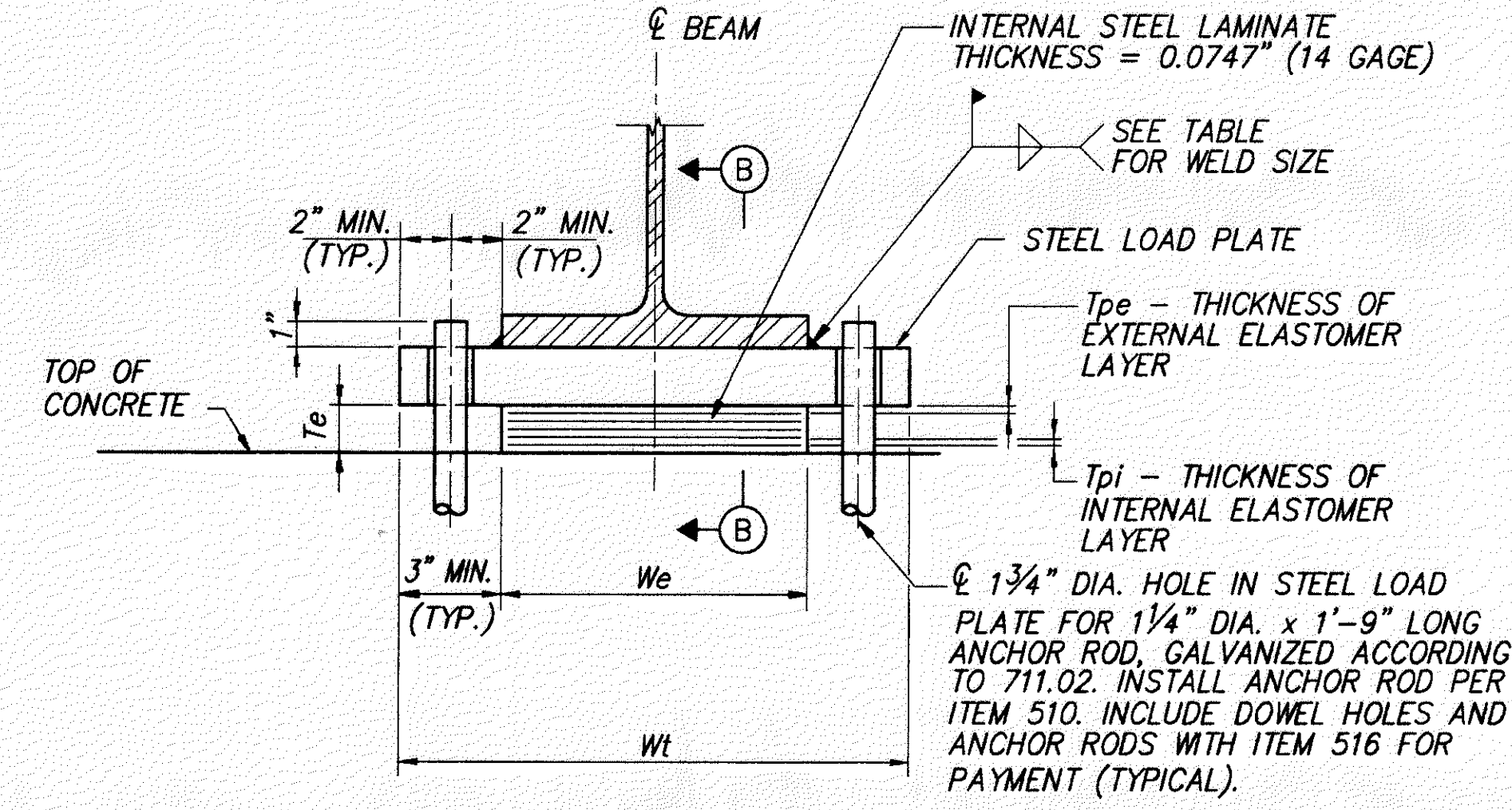

LAMINATED ELASTOMERIC FIXED BEARING AT PIER

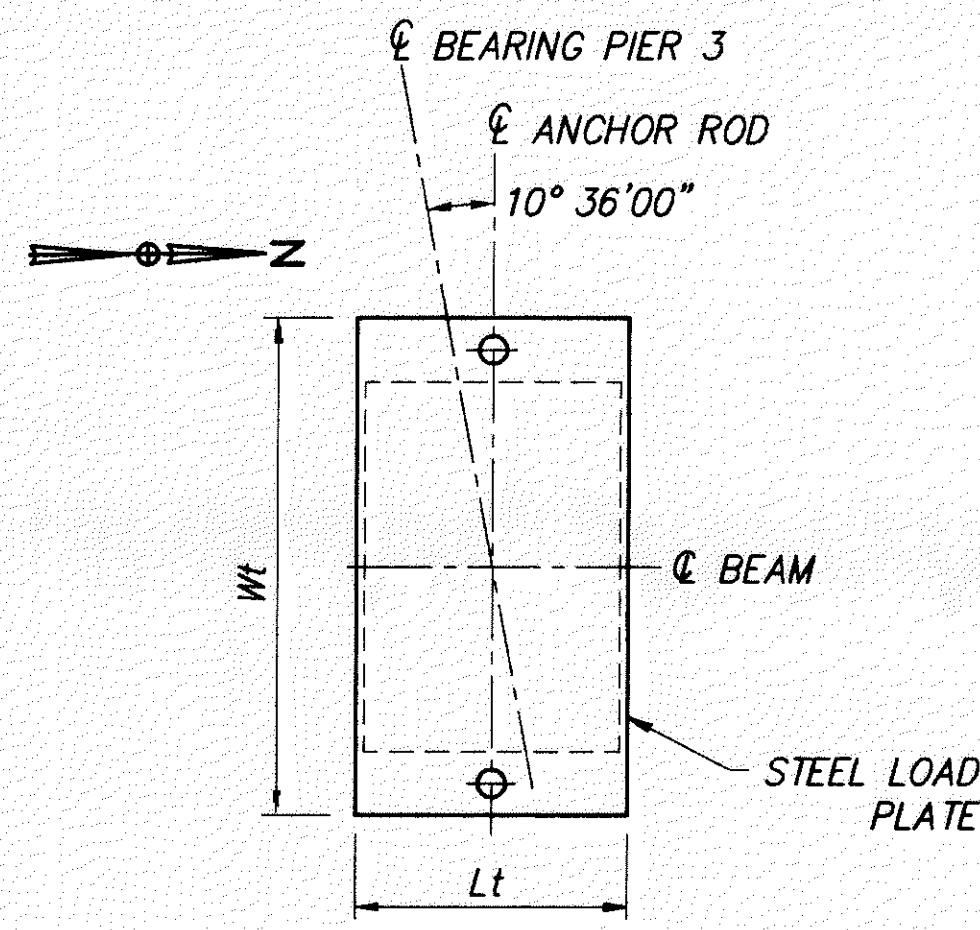
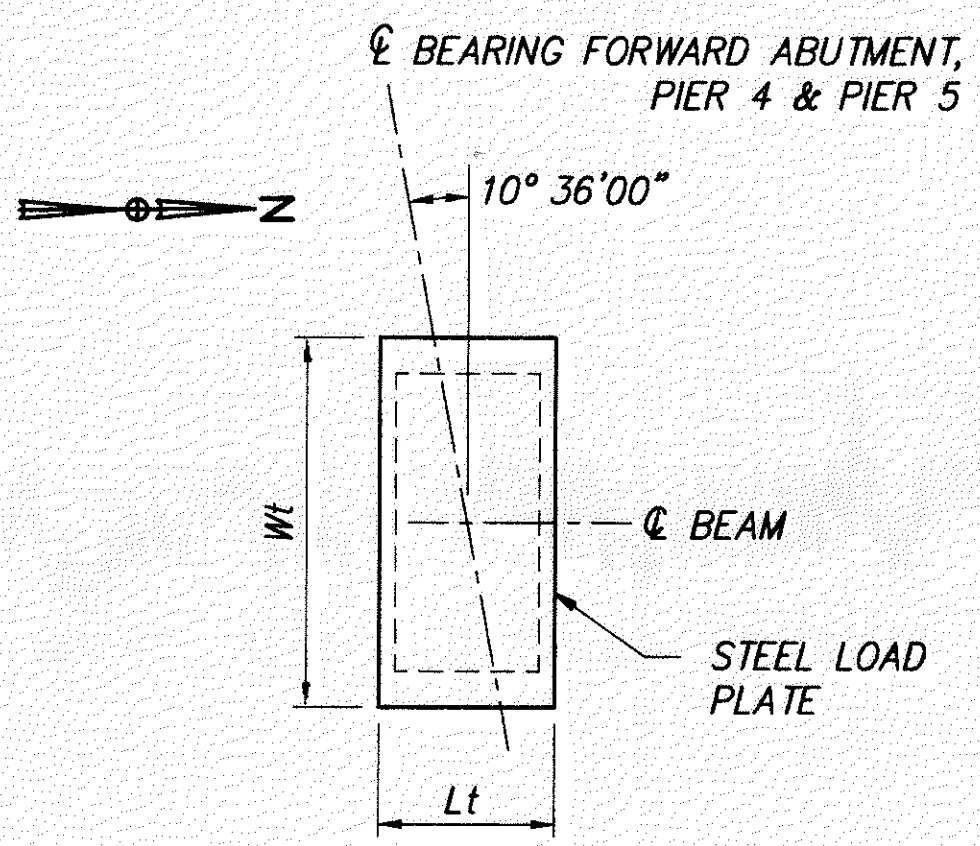
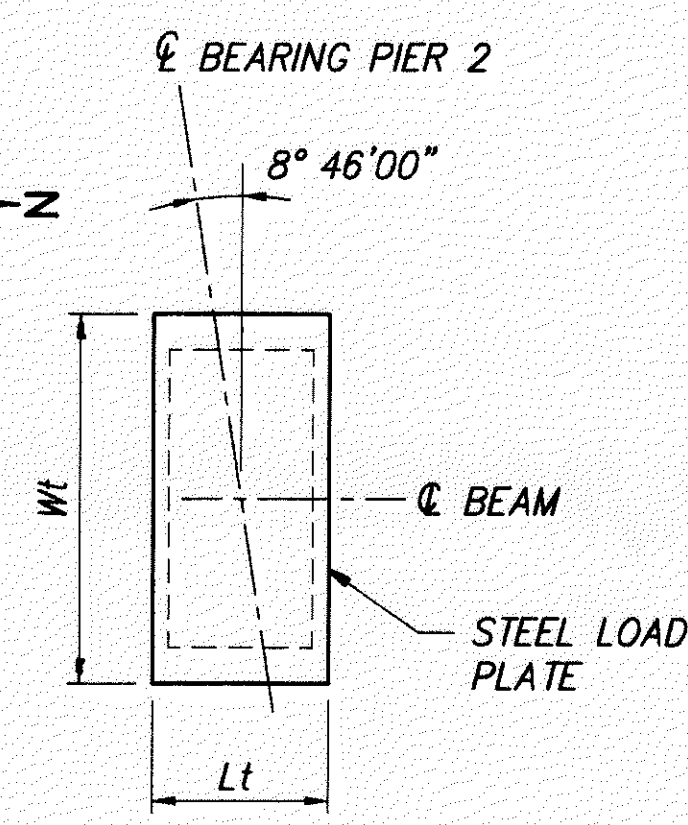
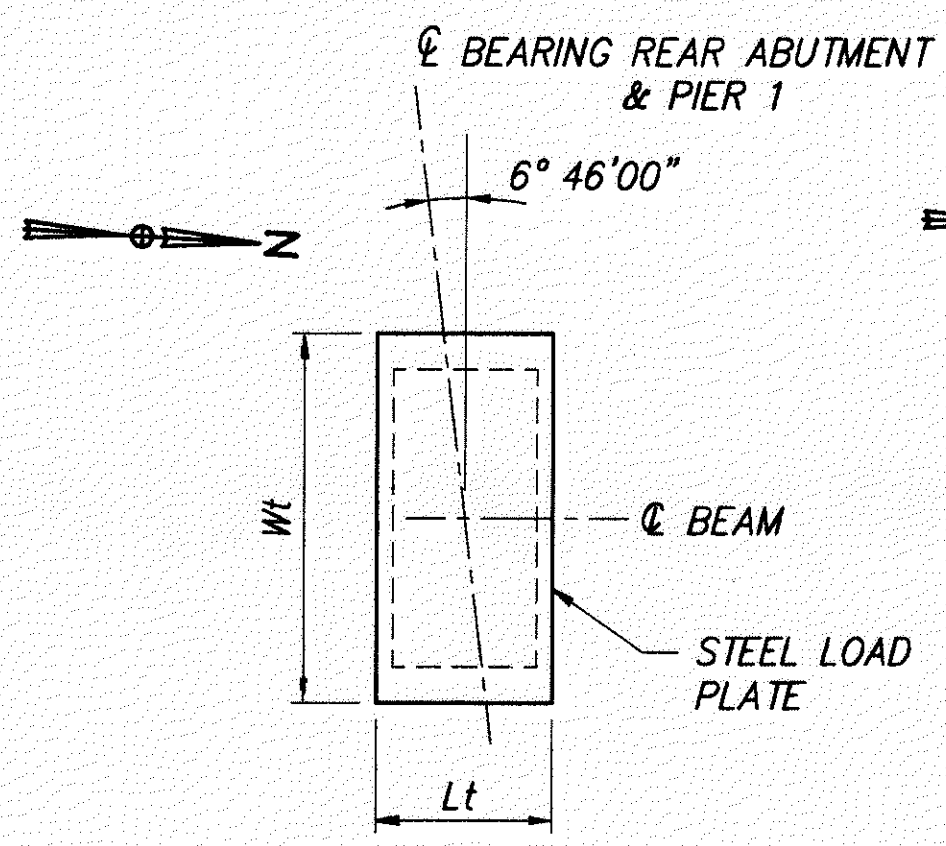

BEARING ORIENTATION PLAN

BEARING LOCATION	MARK NO.	BEARING TYPE	NO. REQ'D.	DEAD LOAD KIPS	LIVE LOAD KIPS	TOTAL LOAD (DL+LL) KIPS	Le in.	We in.	Tpi in.	NO. OF Tpi'S	Tpe (2 EA.) in.	NUMBER OF INTERNAL LAMINATES (14 GAGE)	Te in.	STEEL LOAD PLATE, in.				Tt in.	FILLET WELD SIZE
														Lt	Wt	t1	t2		
REAR ABUTMENT	E1	EXP.	6	41	66	107	11	12	0.24	10	0.17	11	3 9/16	12	13 1/8	1 1/2	-	5 1/16	5/16
PIER 1	E2	EXP.	6	159	81	240	13	20	0.37	4	0.27	5	2 3/8	14	21	2	-	4 3/8	5/16
PIER 2	E3	EXP.	6	173	87	260	13 1/2	21	0.39	2	0.28	3	1 9/16	14 1/2	22	2 1/8	-	3 1/16	5/16
PIER 3	F1	FIXED	6	168	87	255	12	21	0.33	4	0.24	5	2 3/16	13	27	2 1/4	-	4 7/16	5/16
PIER 4	E3	EXP.	6	173	87	260	13 1/2	21	0.39	2	0.28	3	1 9/16	14 1/2	22	2 1/8	-	3 1/16	5/16
PIER 5	E2	EXP.	6	159	81	240	13	20	0.37	4	0.27	5	2 3/8	14	21	2	2 3/4	4 3/4	5/16
FORWARD ABUTMENT	E1	EXP.	6	41	66	107	11	12	0.24	10	0.17	11	3 9/16	12	13 1/8	1 1/2	2 1/4	5 1/16	5/16

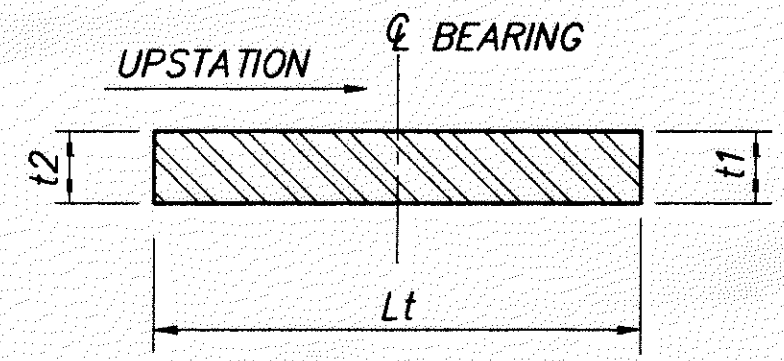

STEEL LOAD PLATE

H:\CT\97125\BRIDGE\9712509.DWG - PLOT SCALE 1:24