

FRONT VIEW OF SEISMIC PEDESTAL
AT BEAM NO. 1 FORWARD ABUTMENT

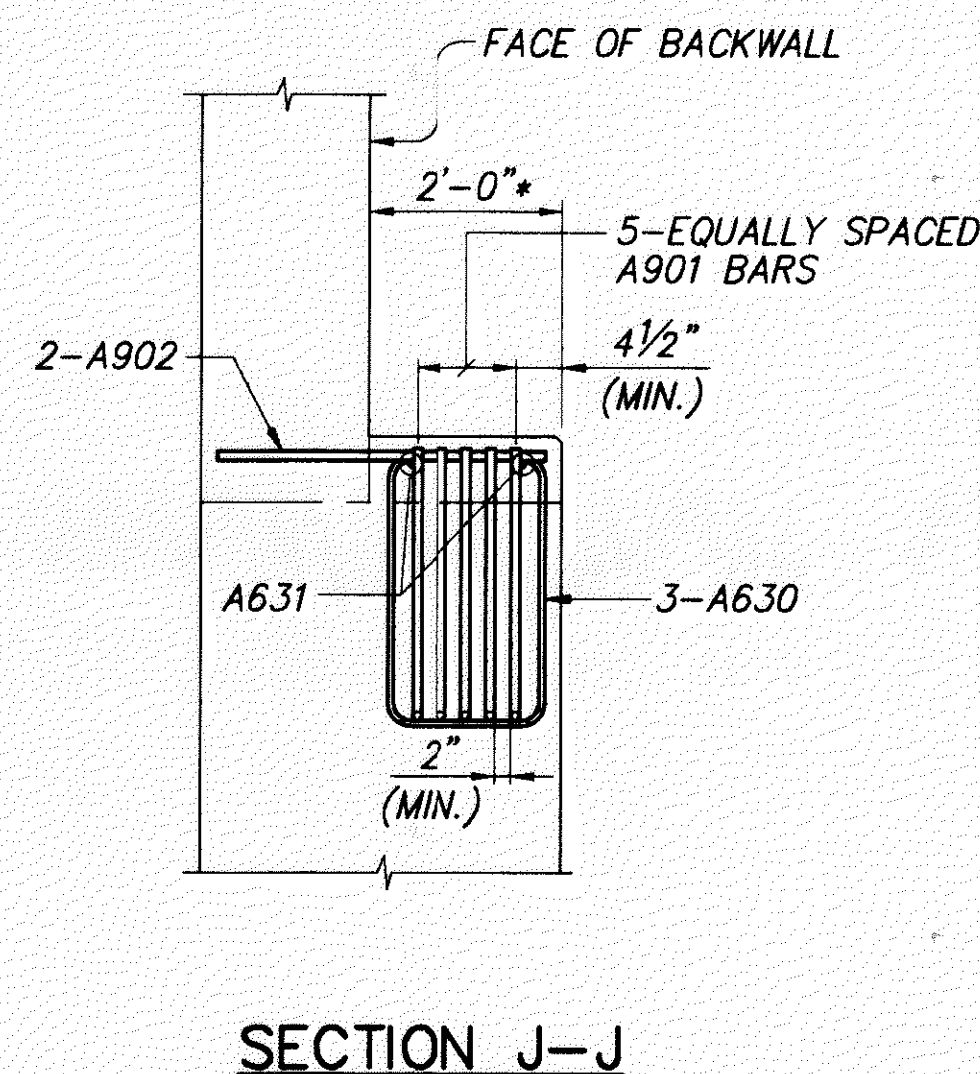
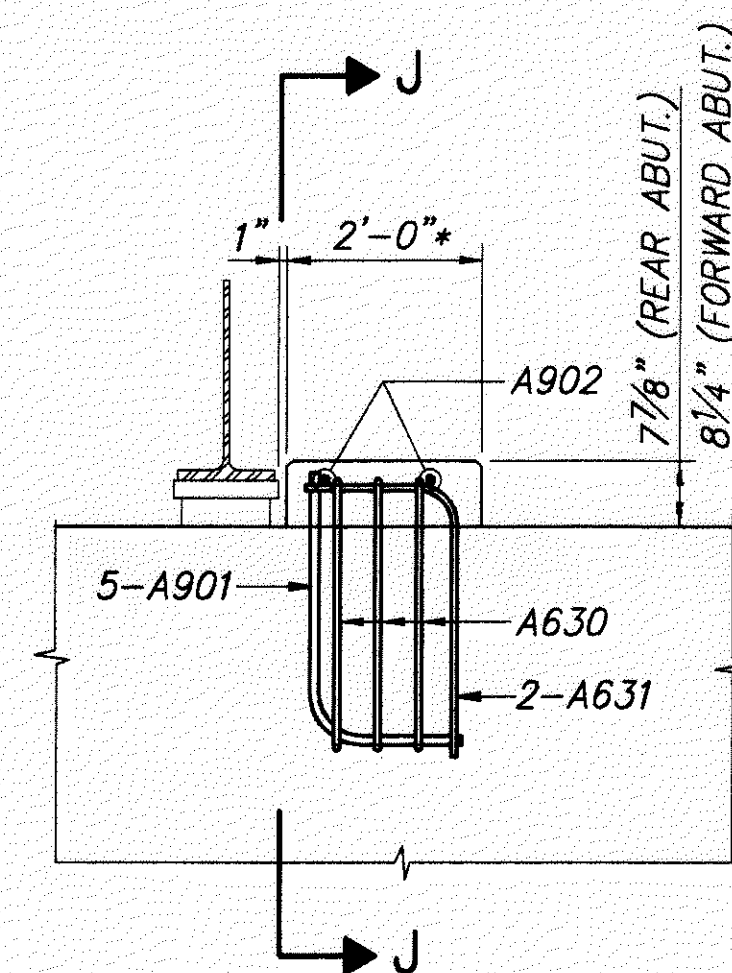

FRONT VIEW OF SEISMIC PEDESTAL
(REAR ABUTMENT BEAM NO. 6 SHOWN, REAR ABUTMENT BEAM
NO. 1 AND FORWARD ABUTMENT BEAM NO. 6 OPPOSITE HAND)

THE 2'-0" WIDTH OF THE PEDESTAL SHALL BE MEASURED PARALLEL TO THE CENTERLINE OF BEARING. THE A901, A631 & A632 BARS SHALL BE PLACED PARALLEL TO THE CENTERLINE OF BEARING. THE A902, A630 & A633 BARS SHALL BE PLACED PARALLEL TO THE BEAMS.

THE LOCATION OF THE MAIN REINFORCEMENT IN THE BEAM SEAT MAY BE ADJUSTED HORIZONTALLY ±1" TO ACCOMMODATE THE A901 BARS.

* - THE SURFACE OF THE THE BEAM SEAT IN THIS AREA SHALL BE FINISHED WITH A SERRATED TROWEL. THE SERRATIONS SHALL BE 1/4" DEEP MINIMUM.

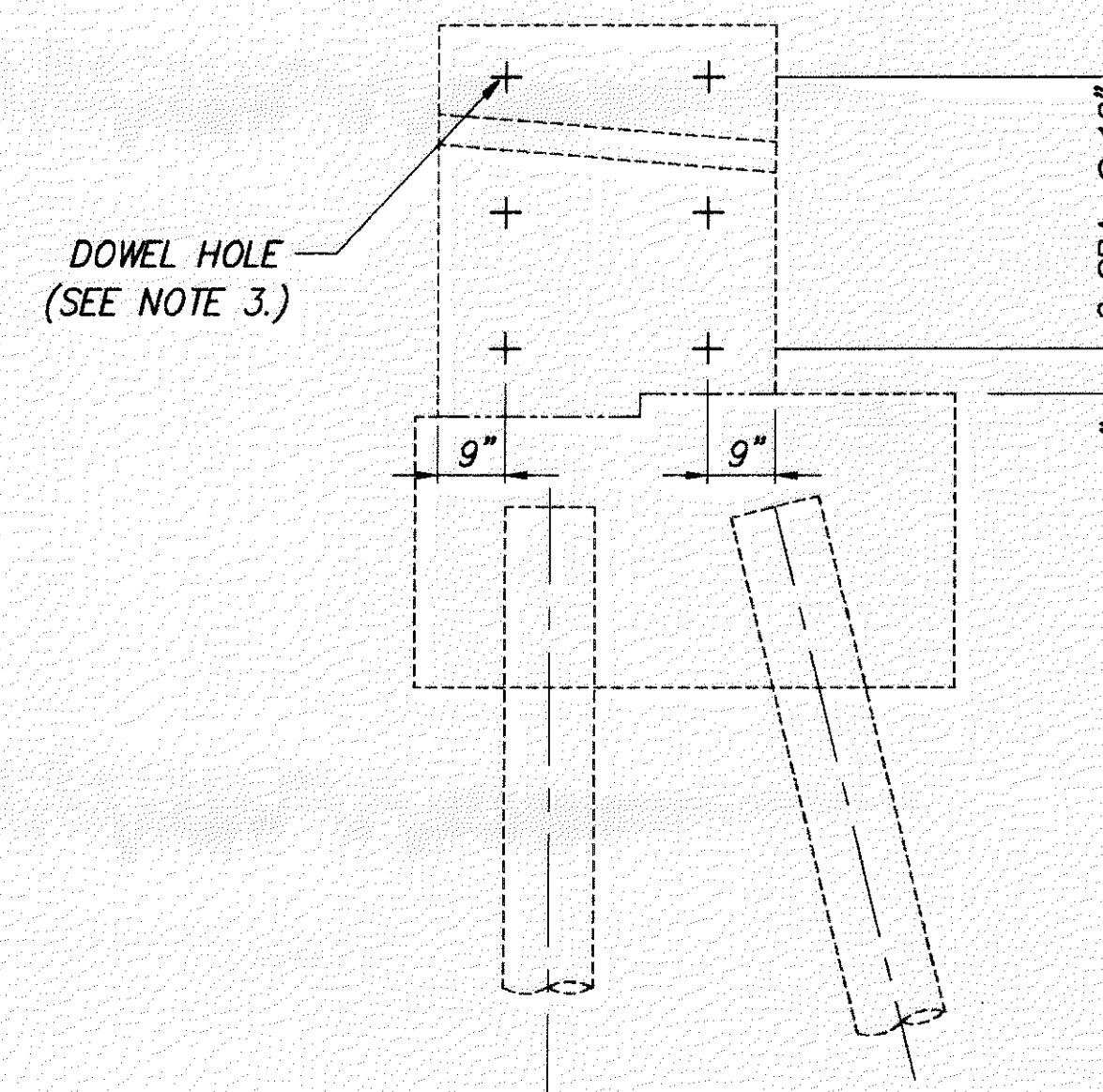

BREASTWALL DOWEL LAYOUT DETAIL
(TYPICAL AT FOUR PLACES)

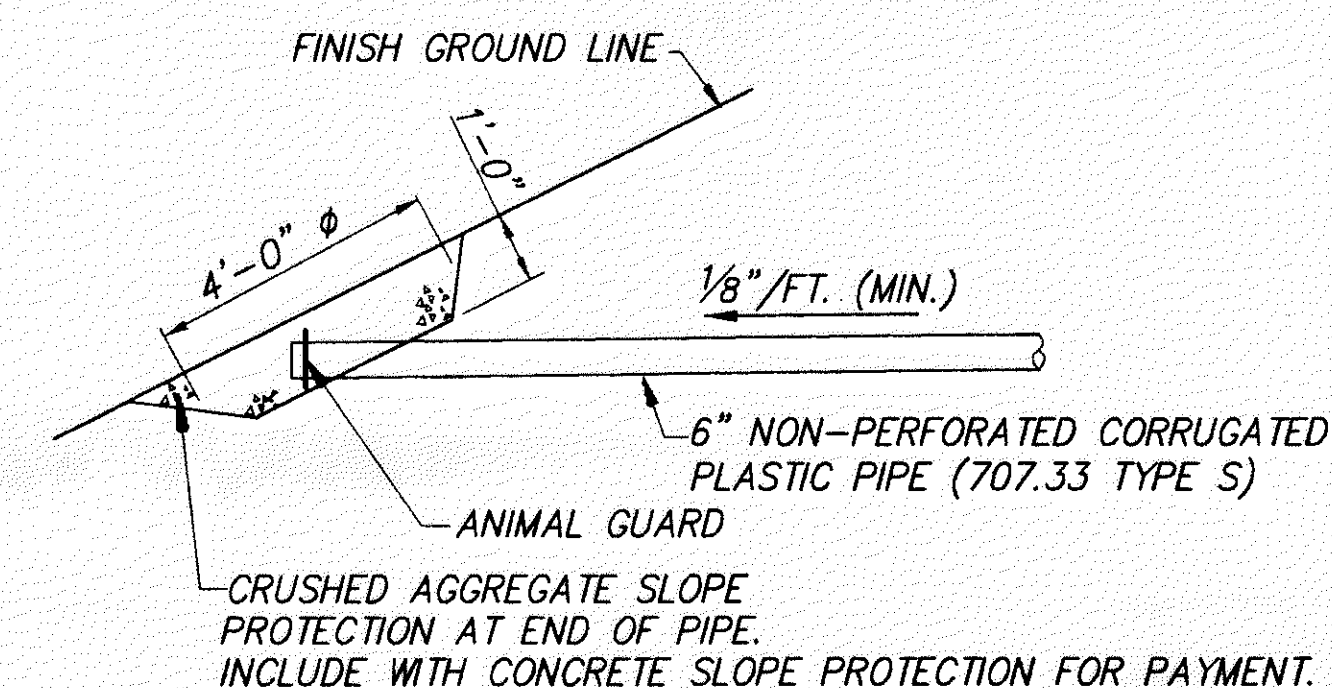

PIPE TERMINATION DETAIL
(TYPICAL AT FOUR PLACES)

NOTES:

1. FOR REAR ABUTMENT PLAN AND ELEVATION, SEE SHEET 16/41.
2. FOR FORWARD ABUTMENT PLAN AND ELEVATION, SEE SHEET 19/41.
3. SEE "DOWEL HOLES" GENERAL NOTE ON SHEET 4/41 FOR INSTALLATION AND PAYMENT INFORMATION.
4. NOTATION: TYP.-TYPICAL; MIN.-MINIMUM; ABUT.-ABUTMENT.

DATE: 06-09-01 - TIME: 11:43 - H:\CT\97125\Bridg\9712524.dwg PLOT SCALE: 1=24