

PIER 2 PLAN

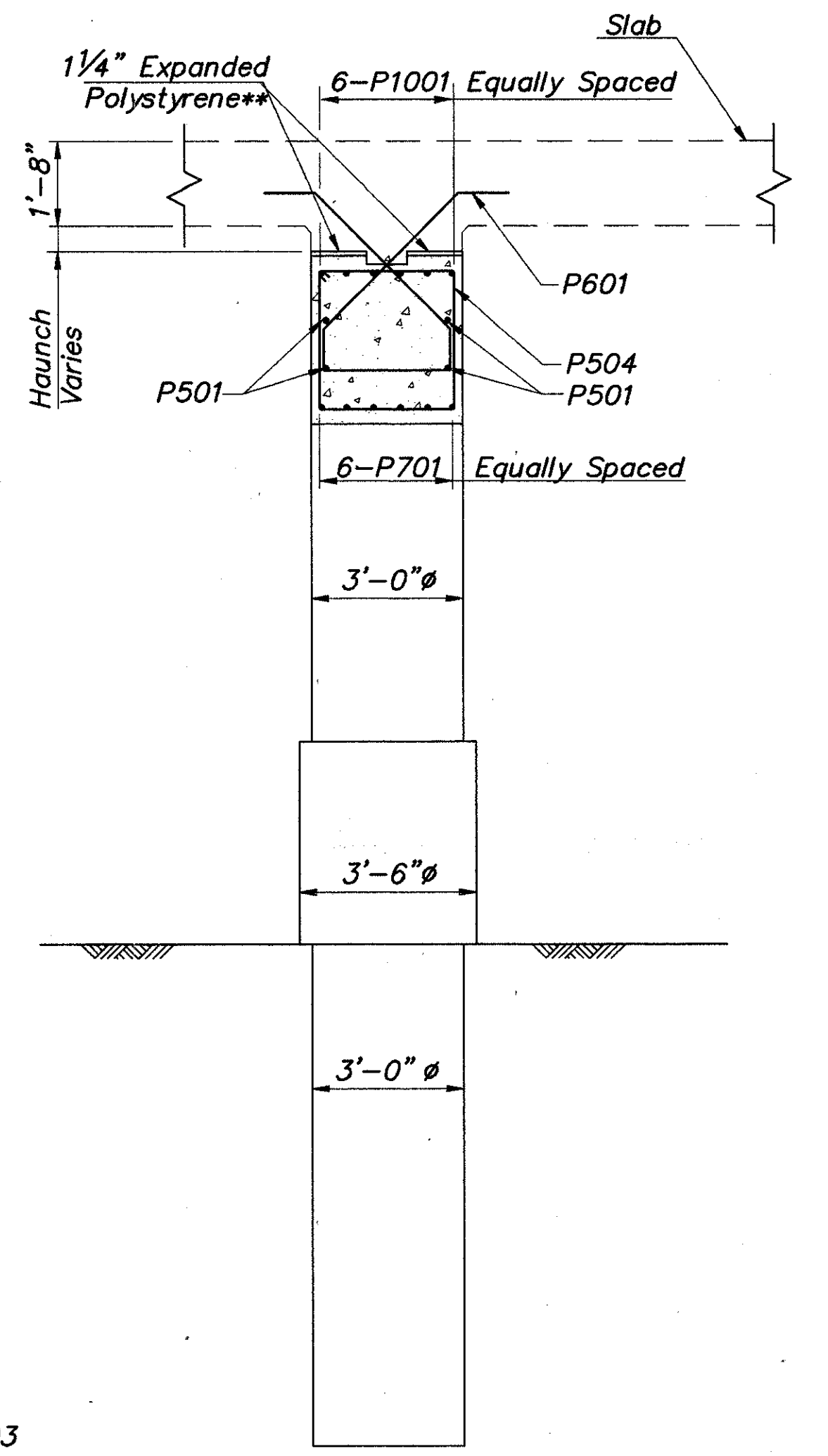

SECTION J-J

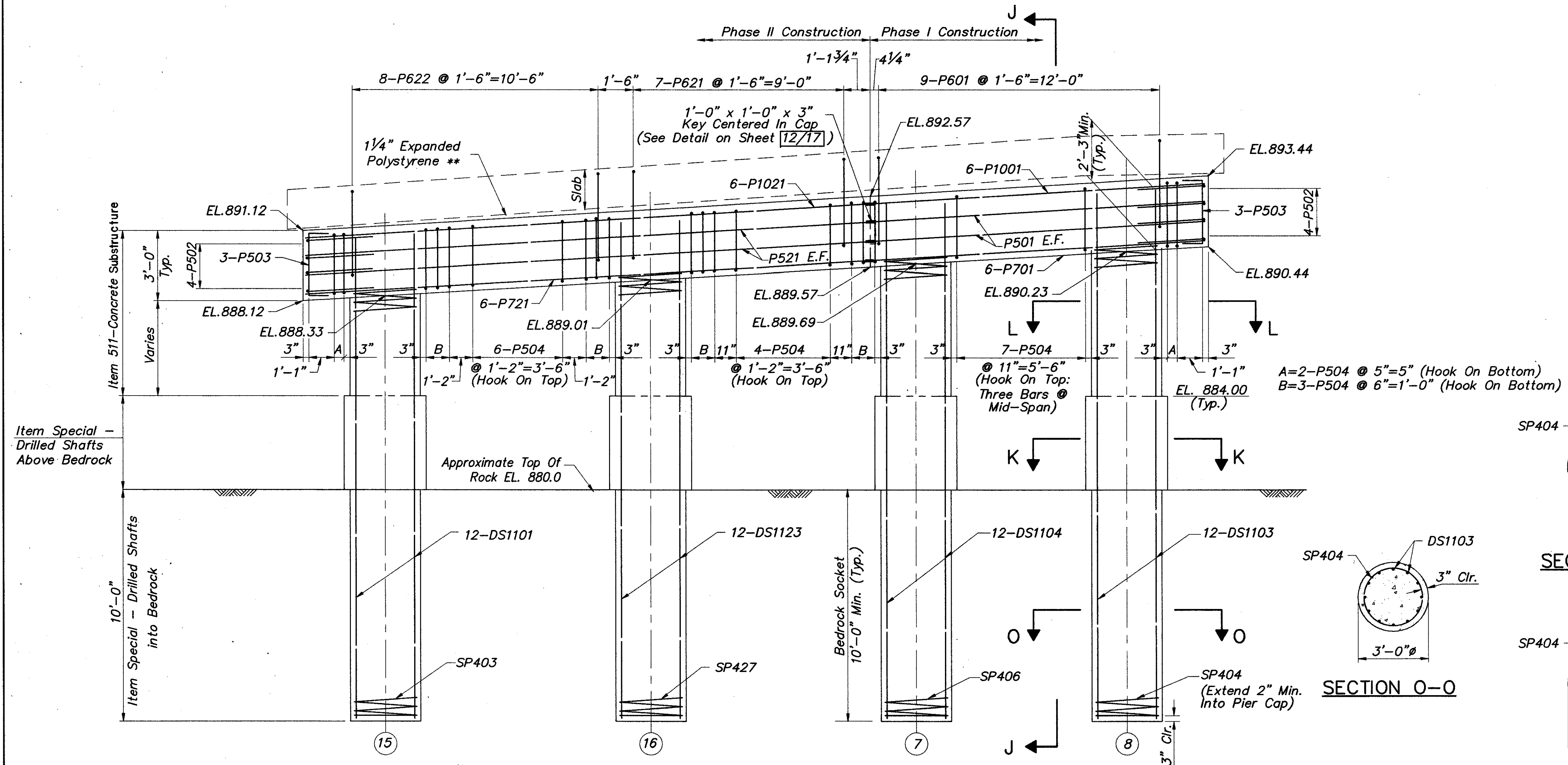

PIER 2 ELEVATION

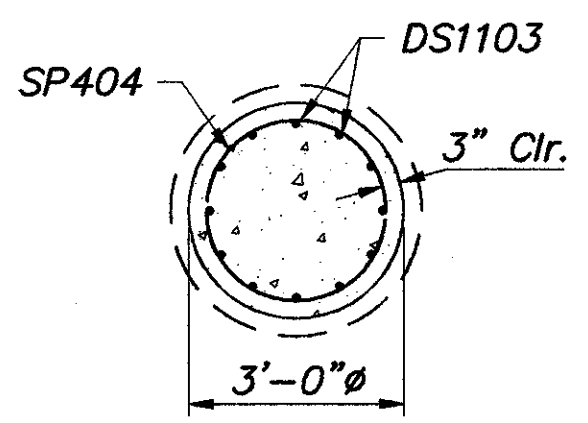

SECTION L-L

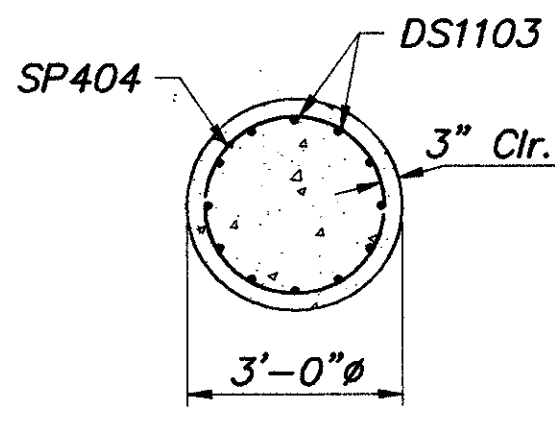

SECTION O-O

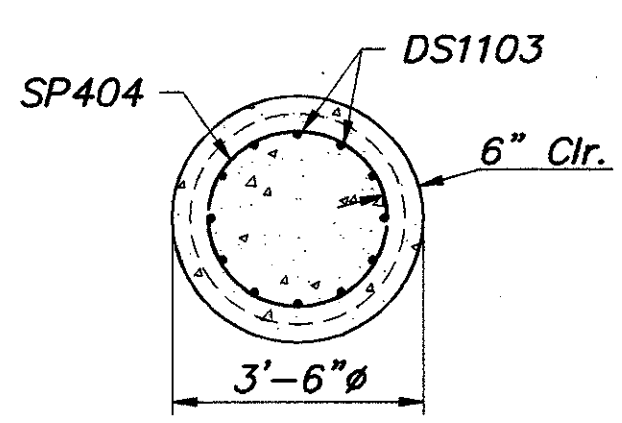

SECTION K-K

Notes:  
 1. Notation: E.F.-Each Face; Ser.-Series; C.J.-Construction Joint; Typ.-Typical; Min.-Minimum; EL.-Elevation; Clr.-Clear

**CT Consultants, Inc.**  
 Engineers • Architects • Planners  
 Willoughby • Mentor • Columbus • North Canton • Canfield  
 13/17  
**PIER 2 PLAN & ELEVATION**  
 BRIDGE NO. LAK-608-0075  
 OVER BIG CREEK  
 LAKE COUNTY

|          |        |        |         |                   |         |
|----------|--------|--------|---------|-------------------|---------|
| DESIGNED | DRAWN  | TRACED | CHECKED | REVIEWED DATE     | REVISED |
| R.L.B.   | R.I.P. | R.I.P. | J.P.R.  | J.E.A.<br>5-29-93 |         |