

LAKE COUNTY
LAK-44-7.22

GENERAL NOTES

DESIGN SPECIFICATIONS: This structure conforms to the requirements of "Design Specifications for Highway Structures" of the State of Ohio, Department of Highways, dated 9-1-57, together with current revisions thereof.

REFERENCE: shall be made to Standard Drawings RB-1-55, revised 2-2-59, CSB-2-56, sheets 2 and 3 of 6, revised 2-2-59; AR-1-57, revised 12-12-60.

CRUSHED AGGREGATE SLOPE PROTECTION: (I-10.04), one foot thick shall be provided as indicated on the General Plan.

POROUS BACKFILL: shall extend upward to the approach slab. Excavation therefore, in excess of that required for construction of the abutment shall be considered as paid for in the bid price per cu. yd. paid for porous backfill.

EXCAVATION: Excavation quantity includes the removal of fill material between the surface of the proposed embankment and the bottom of footings

PILES: shall be driven with a hammer of not less than 11,000 Ft. Lbs. per blow to firm contact with shale. If the length of penetration is approximately equal to the depth to shale according to the bridge foundation investigation report, the firm contact shall be considered as attained when the capacity according to the formula in Sec. 18.05 is not less than the following value for a pile hammer of the indicated energy rating.

HAMMER FT. LB.	ABUTMENTS TONS PER PILE	PIERS TONS PER PILE
11,000	50	48
15,000	45	41

If the energy rating of the hammer is between the ratings as shown above, the required formula capacity shall be determined by interpolation. The design load is 35 tons per pile of the piers and 40 tons per pile at the abutments.

PROCEDURE: the embankment shall be placed and compacted up to the finished spill-thru slope and to the level of the subgrade for a distance of 200 feet back of the abutments, after which excavation shall be made for the abutment. The excavation for Pier #1 and Pier #3 shall not be made until after the embankment is in place.

MACHINE FINISH: The top of the bridge deck slab shall be machine finished, (Sec S-123)

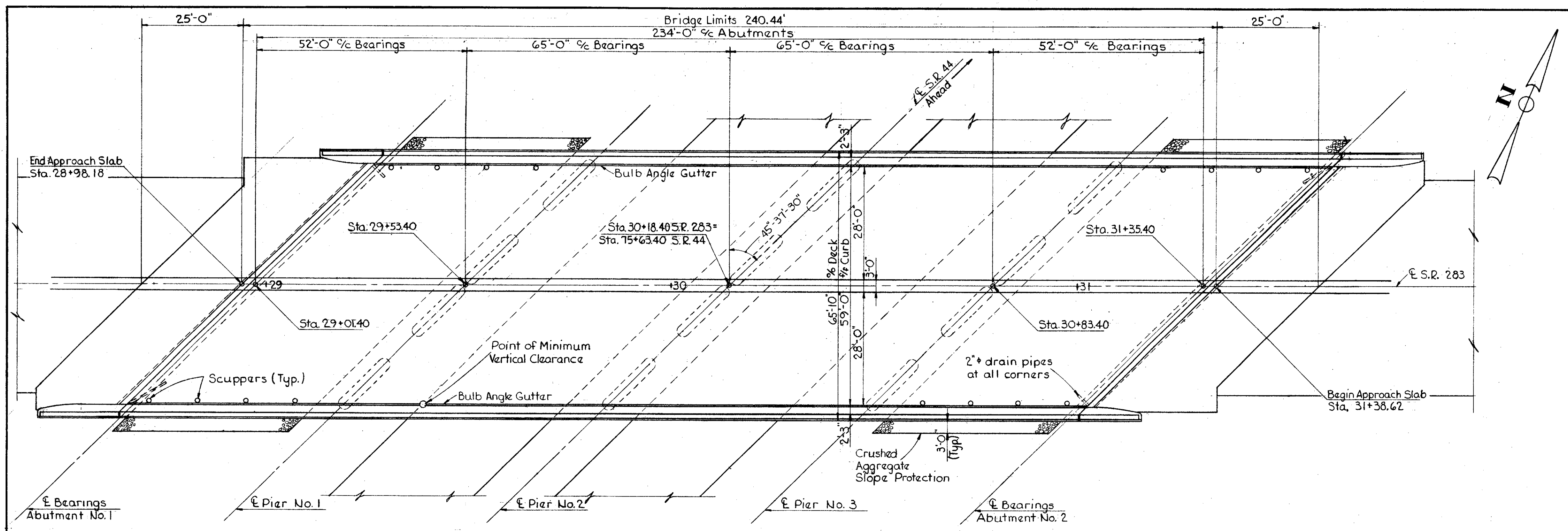

GENERAL PLAN

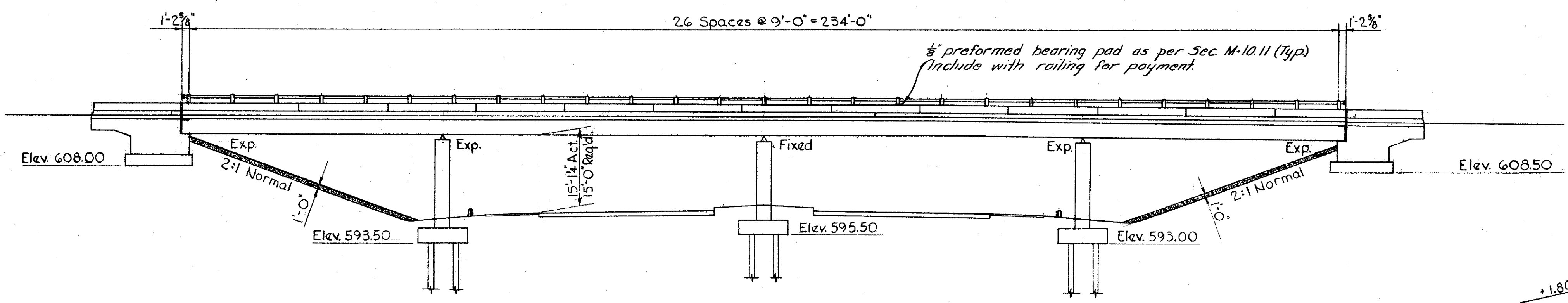

**ELEVATION
ALONG S.R. 283**

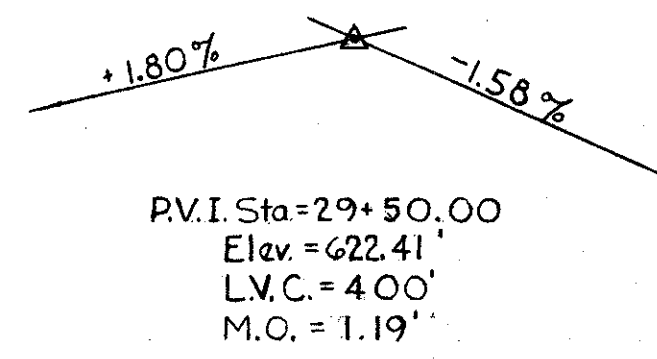

CURVE DATA

ESTIMATED QUANTITIES							
ITEM	TOTAL	UNIT	DESCRIPTION	SUPER.	ABUTS.	PIERS	GENERAL
E-2	1,231	Cu.Yds.	Unclassified Excavation		800	431	
S-1	509	Cu.Yds.	Class "C" Concrete, Superstructure	509			
S-1	166	Cu.Yds.	Class "C" Concrete, Pier Caps and Columns			166	
S-1	206	Cu.Yds.	Class "E" Concrete, Abutments above Footing		206		
S-1	292	Cu.Yds.	Class "E" Concrete, Footings		162	130	
S-3	21	Lin.Ft.	Waterproofing, pre-molded sealing strip		21		
S-4	207,406	Lbs.	Reinforcing Steel	133,270	24,938	49,198	
S-7	396,900	Lbs.	Structural Steel	396,900			
S-8	396,900	Lbs.	Field Painting of Structural Steel	396,900			
S-9	56	Sq. Ft.	1" Preformed Expansion Joint Filler (Type II)		56		
S-14	543	Lin.Ft.	Railing (aluminum rail and supports, concrete parapets)	473	70		
S-16	Lump	Sum	First Test Pile				Lump
S-18	4,400	Lin.Ft.	Steel Piles, I2 BP53		2,000	2,400	
S-29	66	Cu.Yds.	Porous Backfill		66		
S-29	16	Each	Scuppers	16			
I-10	782	Sq.Yds.	Crushed Aggregate Slope Protection				782

PREPARED BY
CAPITOL ENGINEERING ASSOCIATES, DILLSBURG, PA.
FOR
STATE OF OHIO
DEPARTMENT OF HIGHWAYS
DIVISION OF DESIGN AND CONSTRUCTION
BUREAU OF BRIDGES

GENERAL PLAN
BRIDGE NO. LAK-44-0795
S.R. 44 UNDER S.R. 283
LAKE COUNTY
STA. 75+63.40

DESIGNED	DRAWN	TRACED	CHECKED	REVIEWED DATE	REVISED
	J.E.G.				