

SECTION A-A

PRESSURE RELIEF JOINTS ~ TYPES B, C & D

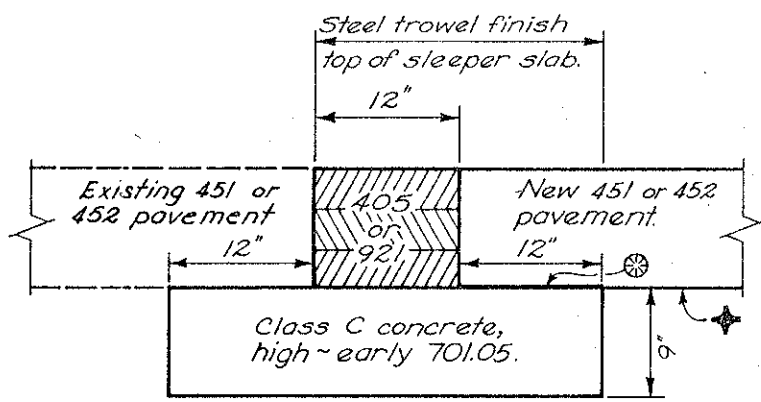

TYPE B

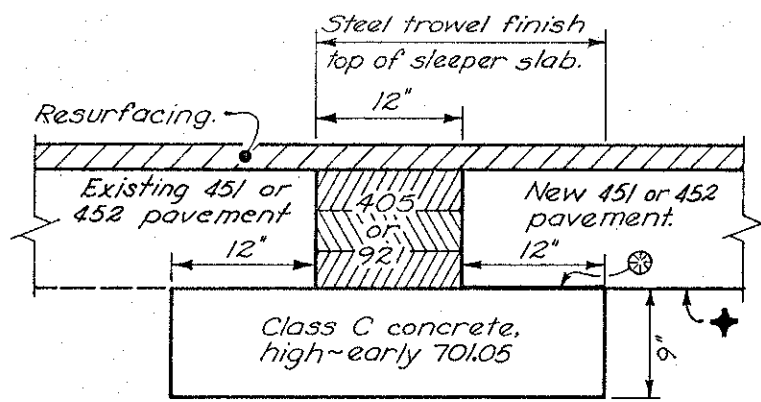

TYPE B ~ WITH RESURFACING

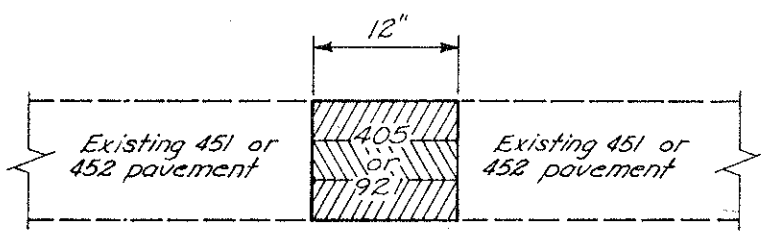

TYPE C

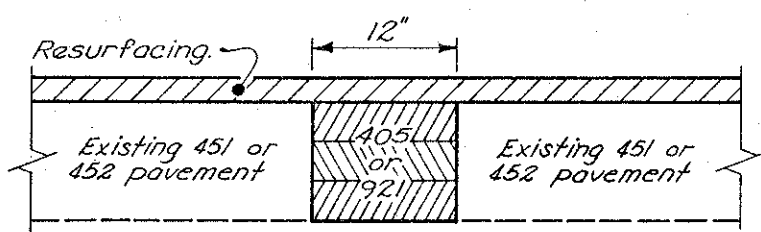

TYPE C ~ WITH RESURFACING

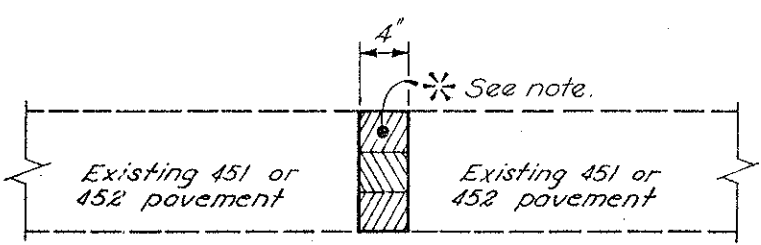

TYPE D

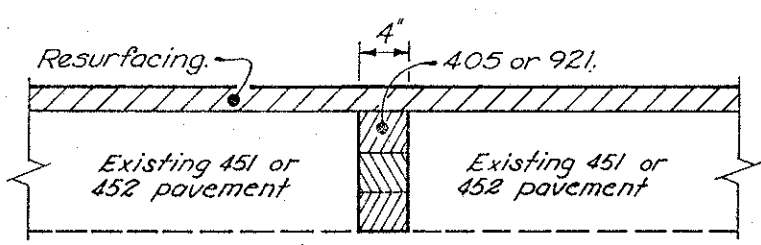

TYPE D ~ WITH RESURFACING

- ⊗ Polyethylene bond-breaker or equal.
- ✦ Care shall be taken to finish the subbase or sub-grade surface smooth and as high or slightly higher than the sleeper slab.

NOTES

ALL JOINTS shall be sawed full depth, however, the cut may be made in two passes. To reduce the possibility of saw binding, joints should be cut, if possible, on overcast days and/or when the temperature is less than 70°.

ON CURBED PAVEMENTS the pressure relief joint shall be cut through to the back of curb. After filling the joint, asphalt concrete shall be formed and tamped in place to conform to the adjacent curb.

SKIEW of the pressure relief joint shall be 12:1 or greater unless otherwise directed by the Engineer.

ANY OF THE PRESSURE RELIEF JOINT TYPES shown may be filled with two or three lifts of loosely compacted 405 or 921 asphalt concrete. *In pavement that is not to be resurfaced in the near future the Type D joint may be filled (in accordance with manufacturer's instructions) with material manufactured for pressure relief joints, such as Meadows Sealtight polyethylene or Froth Pak urethane foam or approved equal.

AGGREGATE DRAINS shall be provided from the low end (or ends) of each pressure relief joint to the embankment slope or ditch inslope. A drain will be required at both ends of the joint if the pavement is crowned with transverse slopes toward both edges. If a feasible outlet is not available for aggregate drains, then metal pipe underdrains, with perforated pipe and aggregate backfill, shall be provided instead of aggregate drains and the pipe extended to a suitable outlet. The material above the filter aggregate of the drain in paved shoulder area may be the same as the shoulder pavement or may be the same as the asphalt material used in the pressure relief joint and included in 605 for payment.

MEASUREMENT of the pressure relief joint for pay purposes shall be along the centerline of the joint, edge to edge of pavement or back to back of curbs. Payment shall be per linear foot for Item Special, Pressure relief joint, Type —, which shall include all work and materials necessary to complete the joint except for the aggregate drains or pipe underdrains which shall be constructed and paid for as Item 605.

CEMENT other than the 701.05 specified may be used if approved by the Engineer, provided an accelerating admixture meeting the requirements of ASTM-C494 Type C or E, and an air entraining admixture meeting the requirements of 705.10 is added at the mixer.

BUREAU OF LOCATION AND DESIGN OHIO DEPARTMENT OF TRANSPORTATION	
PRESSURE RELIEF JOINT TYPES B, C & D	
STANDARD CONSTRUCTION DRAWING	
BP-11	
APPROVED	ENGR., L&D.
DATE	1-30-84