

TRANSVERSE JOINTS

CONTRACTION JOINTS

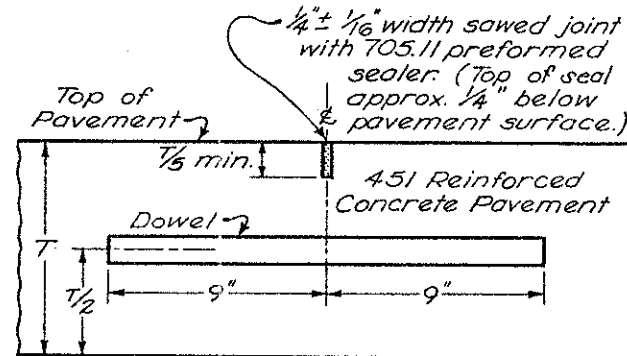

SECTION - 451 PAVEMENT

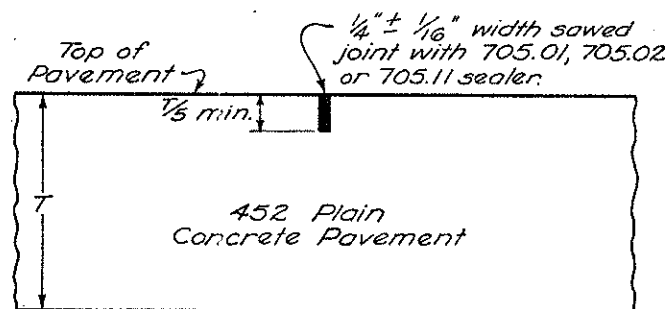

SECTION - 452 PAVEMENT

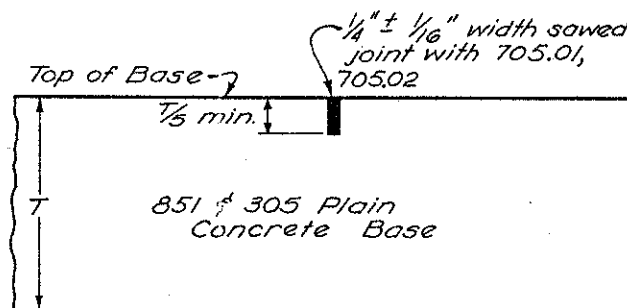

SECTION - 851 & 305 BASE

CONSTRUCTION JOINT

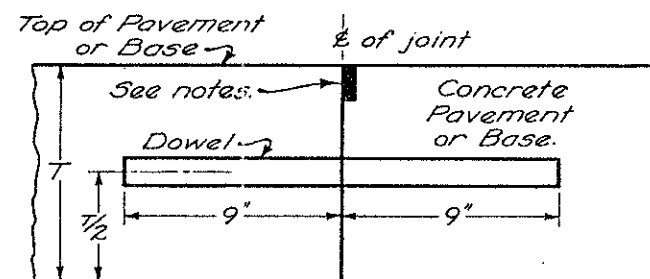

SECTION THROUGH CONSTRUCTION JOINT

EXPANSION JOINT

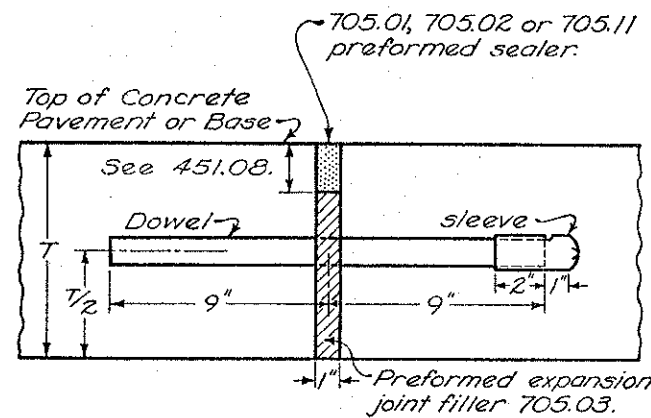

SECTION THROUGH EXPANSION JOINT

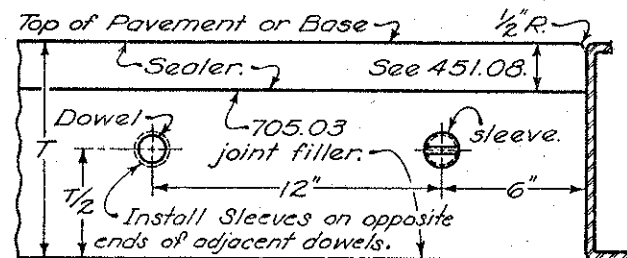

SIDE ELEVATION OF EXPANSION JOINT

GENERAL: Notes and details shown on this drawing shall be considered in conjunction with and supplemental to the pertinent specifications for portland cement concrete pavements and bases, and incidentals related thereto.

All joints shall be constructed normal to the centerline of the pavement lane unless otherwise directed.

Where dowels are specified, they shall be round, straight steel bars of the size indicated in the following table, and shall be shop coated with a suitable rust inhibitor. Dowels shall be spaced at 12" centers, beginning 6" from the longitudinal joint.

DOWEL SIZE	
(T) THICKNESS OF PAVEMENT	DIAMETER OF DOWEL
8.5" or less	1"
8.6" to 10"	1 1/4"
over 10"	1 1/2" or as shown on plan

ASSEMBLY: Each joint assembly used to hold dowels in position shall be continuous between longitudinal joints or between longitudinal joint and pavement edge. The assembly shall be firmly held in proper position by at least eight 1/2" steel pins driven at an angle to brace the assembly from lateral and vertical displacement during the placing of the concrete. These pins shall be at least 18" in length. Two of these pins shall be driven opposite each other at each end

of the assembly and the remaining pins shall be driven in staggered positions on each side of the assembly. In exceptional cases where it is impractical to use the 18" length pins, such as where hardpan or rock is encountered, the Engineer may authorize use of shorter pins provided the assembly is held firmly. Where the assembly is placed on granular material which may allow settlement or distortion of the assembly, a minimum of 6 steel plates each having a bearing area of approximately 25 square inches and a cross-section which will not bend under the imposed load, shall be placed under the assembly. One plate shall be used at each of the four end pins. The remaining plates shall be spaced uniformly on each side of the assembly. The method of staking and placing bearing plates shall be approved by the Engineer.

Dowel spacing is shown for pavement lanes of even foot widths. Where other widths are specified, standard cages may be used with dowel spacings adjusted as follows:

The 6" dowel spacing shall be maintained at the longitudinal joint. The spacing at the outer edge of the lane may be increased up to 12". Where an odd width of lane occurs, a dowel shall be placed 6" from the outer edge of the lane if the standard cage would provide for a space exceeding 12". Such a dowel shall be held rigidly in proper position by a method satisfactory to the Engineer, or a dowel cage of greater length than required may be used by cutting the assembly and splicing to attain the required length.

This drawing is intended for use with a uniform depth pavement. When the project involves the placing of variable depth pavement, the joint components shall be held in place in accordance with the method shown in the plan or as approved by the Engineer.

EXPANSION JOINTS: Expansion joint filler shall be held rigidly in position and shall be continuous for the full width of each lane. The face of the expansion joint shall be perpendicular to the concrete surface and shall not be skewed horizontally except when abutting a skewed bridge approach slab.

Smooth dowels shall be used, and free movement shall be provided by applying a coating of an oil such as S.A.E. 140 or other "bond-breaking" material just prior to placing the concrete. One free end of each dowel shall be equipped, after coating, with a sleeve of metal or other approved material approximately 3' long, designed with crimped end and overlapping seams, fitting closely around the dowel. Each sleeve shall be provided with a depression or inferior projection to act as a stop for the dowel, sufficiently distant from the crimped end to allow 1" for longitudinal dowel movement with pavement expansion. In lieu of this requirement, any other means may be used if approved by the Director.

Proper size dowel holes shall be punched or drilled into the preformed expansion joint filler in order to insure tight fitting dowels.

CONTRACTION JOINTS: All contraction joints in 451 reinforced concrete pavement shall be dowelled. Contraction joints in plain concrete base or pavement shall be dowelled if within 500' of a pressure relief joint. Contraction joints without dowels shall be skewed with the right edge of the joint 4 feet ahead of the left edge in the direction of travel for a 24-foot wide pavement.

To provide for longitudinal movement at the joint, dowels shall be smooth and coated with a bond breaking material

such as S.A.E. 140 oil just prior to placing the concrete.*
Contraction joints of the type specified shall be spaced in accordance with the following table:

CONTRACTION JOINT SPACING		
TYPES OF PAVEMENT OR BASE	MAXIMUM SPACING BETWEEN JOINTS	
451 Reinforced Concrete Pavement	40 lin. ft.	
452 Plain Concrete Pavement	17 lin. ft.	Skewed when not dowelled
851 & 305 Plain Concrete Base	20 lin. ft.	

CONSTRUCTION JOINTS: Smooth dowels shall be used in transverse construction joints in all portland cement concrete pavement and base. The joint shall be formed by using an adequate bulkhead that will provide a straight joint. The bulkhead shall have openings provided for dowel bars spaced as outlined under "ASSEMBLY." The bulkhead shall be shaped to fit the typical section of the pavement or base. Dowels shall be held rigidly in position during the placing of the concrete.

Construction joints in reinforced concrete pavement may be located at a contraction joint or between contraction joints, provided they are not closer than 10 feet to another parallel joint. In plain concrete pavement or concrete base a construction joint shall not be located closer than 5 feet to another parallel joint.

Kerf and seal conforming in all respects to details shown for contraction joints shall be provided at each construction joint in concrete pavement and base.

SEALING BASE CONTRACTION JOINTS:

All contraction joints for plain concrete bases shall be sealed as detailed hereon and the cost included in the unit price bid for Item 305 or 851.

The requirement for sealing base contraction joints may be waived by the Engineer provided the joints will not be contaminated by traffic or construction equipment and will be cleaned and free of all foreign material just prior to the overlaying of the surface courses.

* Dowel coatings conforming to the requirements of supplemental specification 948, Type A do not require a bond breaker.

BUREAU OF LOCATION AND DESIGN OHIO DEPARTMENT OF TRANSPORTATION	
TRANSVERSE PAVEMENT JOINTS	
STANDARD CONSTRUCTION DRAWING	
BP-4	
APPROVED: <i>[Signature]</i> ENGR. L. & D.	

DATE
6-1-65
1-10-67
12-1-68
1-1-71
12-6-76
7-16-81