

# CONTRACTION JOINTS

# NOTES

CONTRACTION JOINT SPACING	
TYPES OF PAVEMENT OR BASE	MAXIMUM SPACING BETWEEN JOINTS
Item 451 Reinforced Concrete Pavement	6.5 m
Item 452 Plain Concrete Pavement <sup>[1]</sup>	5.0 m
Item 305 Concrete Base	6.0 m

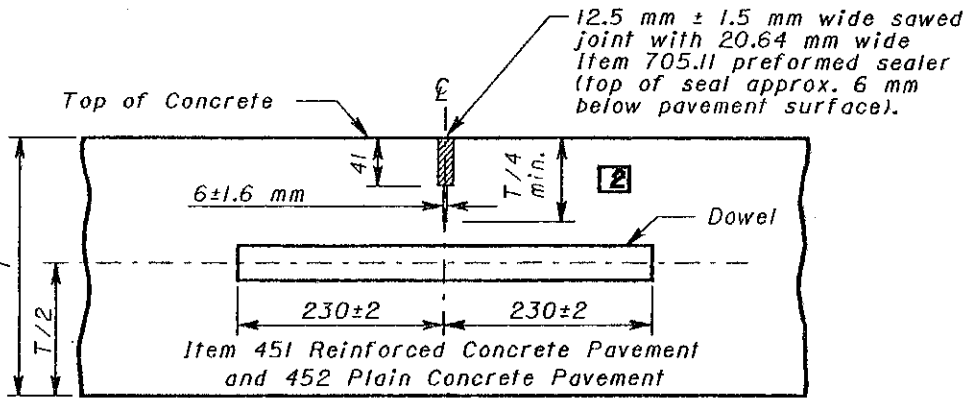

SECTION - ITEM 451 & 452

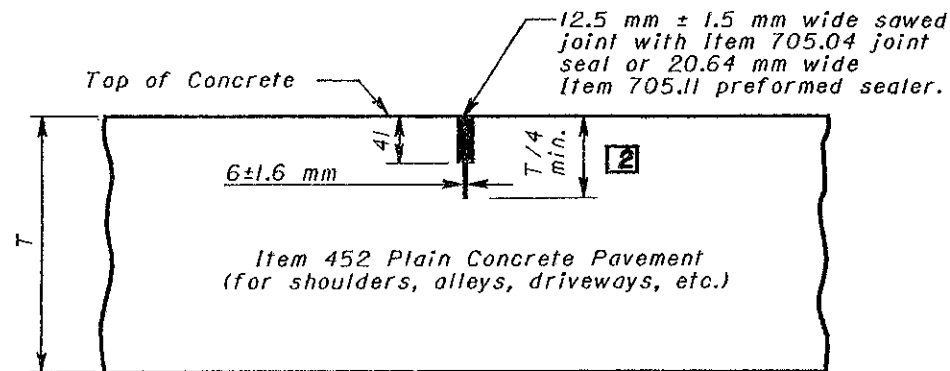

SECTION - ITEM 452

<sup>[2]</sup> Where  $T > 255$  mm, the sawcut depth shall be  $T/3$ .

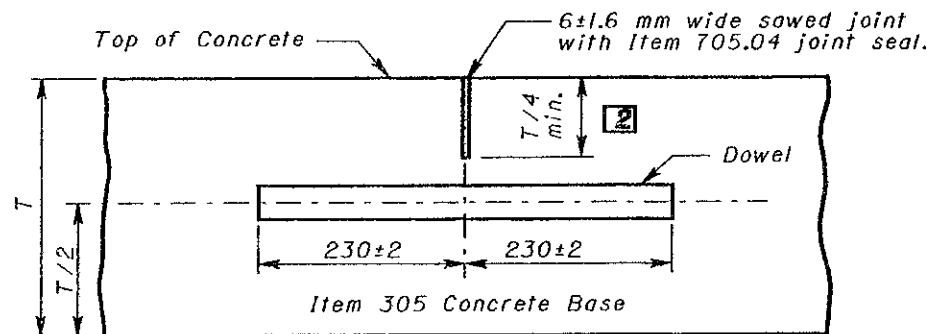

SECTION - ITEM 305

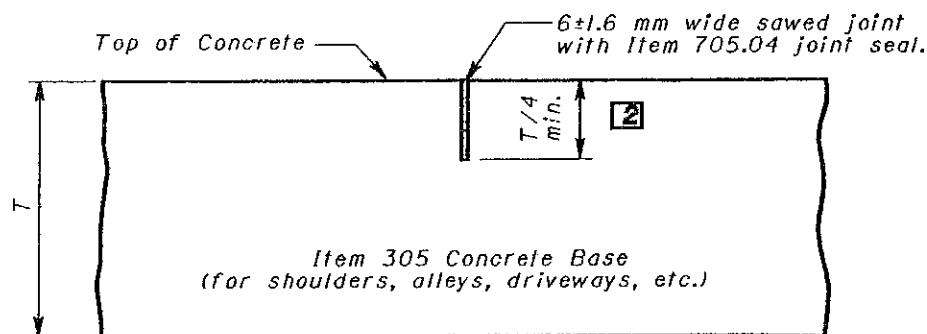

SECTION - ITEM 305

**GENERAL:** Notes and details shown on this drawing shall be considered in conjunction with and supplemental to the pertinent specifications for portland cement concrete pavement and bases, and related incidentals.

**JOINT COMPONENTS:** This drawing is intended for use with a uniform depth pavement. When the project involves the placing of variable depth pavement, the joint components shall be held in place in accordance with the method shown in the plans or as approved by the Engineer.

**CONTRACTION JOINTS:** All contraction joints in Item 451 Reinforced Concrete Pavement shall be dowelled. Contraction joints in Item 452 Plain Concrete Pavement and Item 305 Concrete Base shall be dowelled where they are located in mainline pavement, ramps, acceleration/deceleration lanes, or collector/distributor lanes, or in shoulders within 150 m of a pressure relief joint.

Contraction joints in Item 305 Concrete Base and in Item 452 Plain Concrete Pavement shall not be dowelled in alleys, private drives, or commercial drives.

Contraction joints of the type specified shall be spaced in accordance with the Contraction Joint Spacing table:

# EXPANSION JOINT

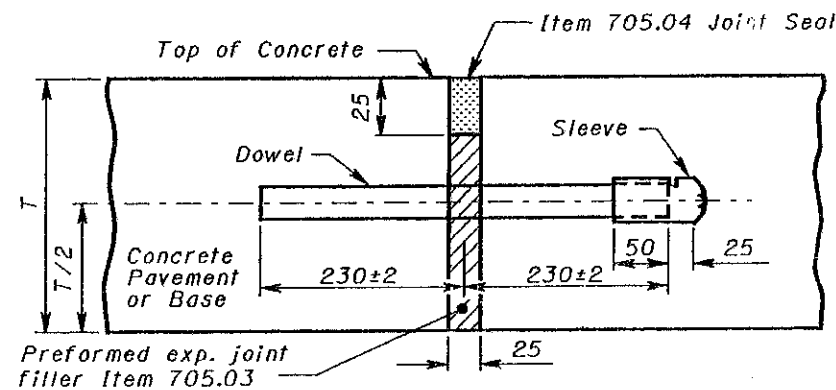

SECTION THROUGH EXP. JOINT

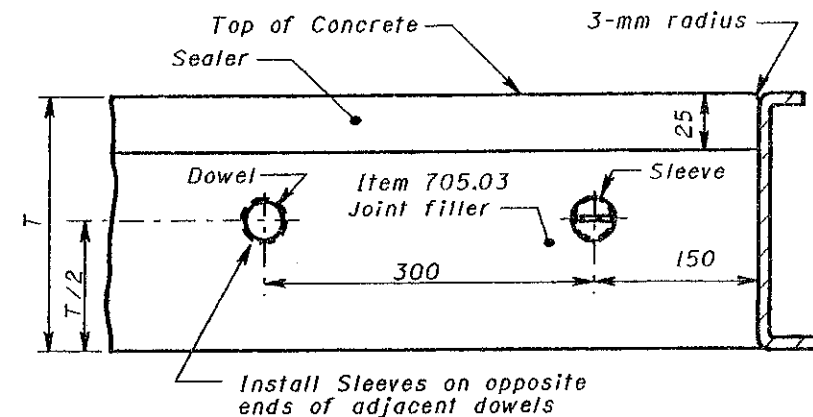

SIDE ELEVATION OF EXP. JOINT  
(through Concrete Pavement or Base)

<sup>[1]</sup> Where Item 452 Plain Concrete Pavement (for shoulders, etc.) is being placed and tied longitudinally to Item 451, Reinforced Concrete Pavement, or Item 305, Concrete Base the joints in Item 452 shall match the spacing alignment, sawing, and sealing requirements of the joints in Item 451 or 305.

**CONSTRUCTION JOINTS:** In plain concrete pavement or concrete base a construction joint shall not be located closer than 1.8 m to another parallel joint.

Kerf and seal conforming in all respects to details shown for contraction joints shall be provided at each construction joint in concrete pavement and base.

**SEALING BASE CONTRACTION JOINTS:** All contraction joints for concrete base shall be sealed as detailed on this drawing and the cost included in the unit price bid for Item 305.

# CONSTRUCTION JOINT

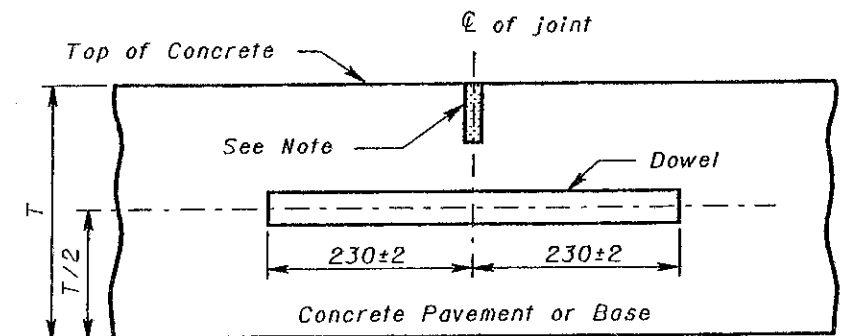

SECTION THROUGH CONSTRUCTION JOINT

All dimensions are in millimeters unless otherwise noted.



This Drawing Replaces BP-2.2.

OHIO DEPARTMENT OF TRANSPORTATION

TRANSVERSE PAVEMENT JOINTS

DATE  
10-28-94  
4-8-97  
10-21-97

STANDARD CONSTRUCTION DRAWING BP-2.2M

APPROVED *Roy F. Sutherland*