

ROADWAY DETAILS

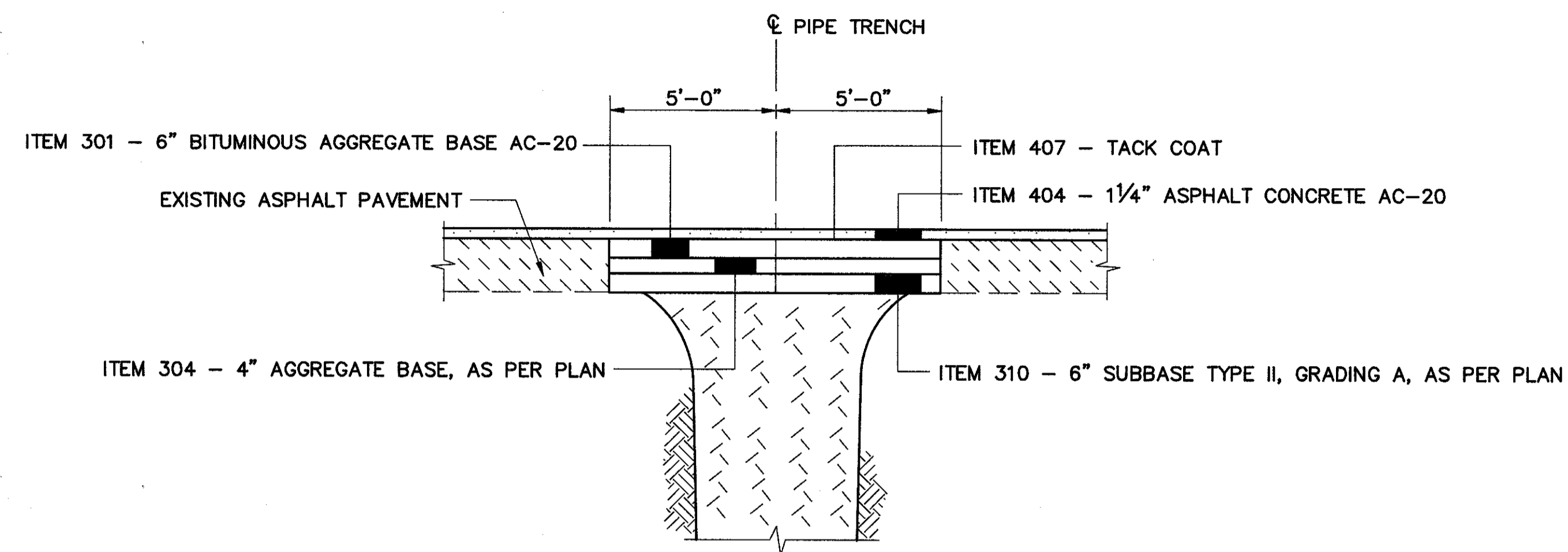

HAWK AVENUE STA. 11+80.00 TO STA. 11+90.00
 TEXAS AVENUE STA. 11+40.00 TO STA. 11+50.00
 JEREMY AVENUE STA. 11+35.00 TO STA. 11+45.00

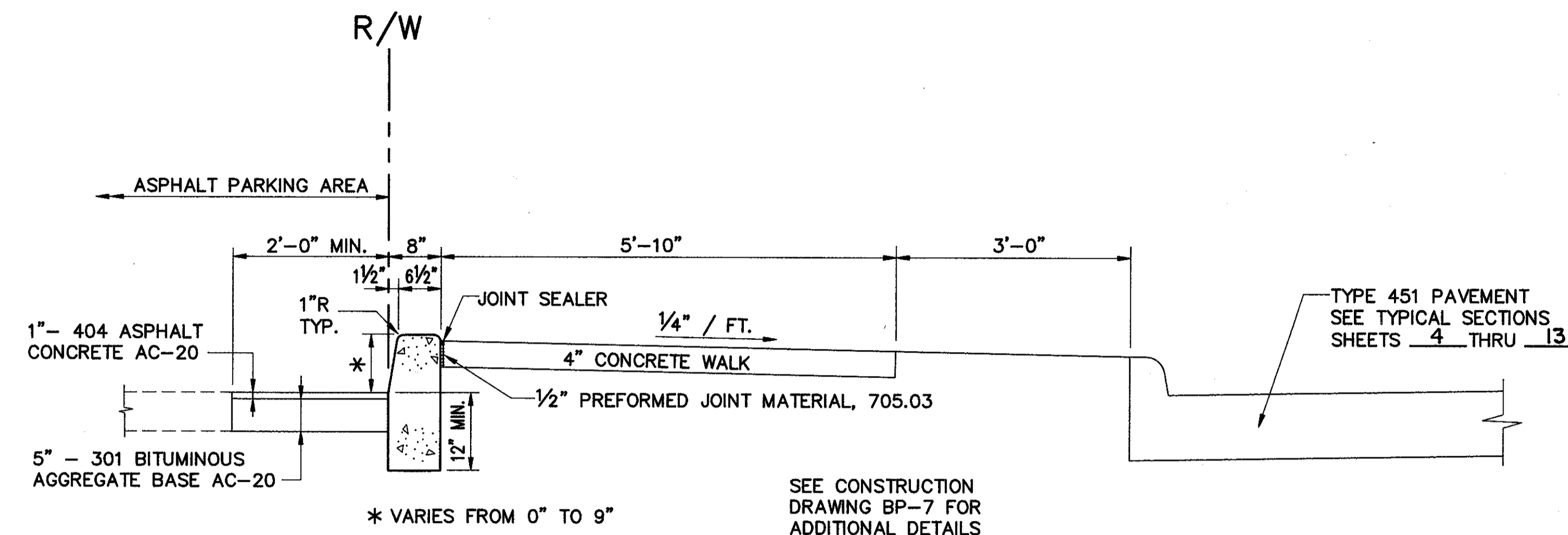

LAKESHORE BLVD. STA. 7+35.00 TO STA. 7+83.00 LEFT
 LAKESHORE BLVD. STA. 8+17.00 TO STA. 8+40.00 LEFT
 LAKESHORE BLVD. STA. 13+13.00 TO STA. 13+87.00 LEFT

