

PAVEMENT REPLACEMENT
 * SEE TRENCH DETAIL SHEET 26

PAVEMENT PLANING
 PORTLAND CEMENT CONCRETE

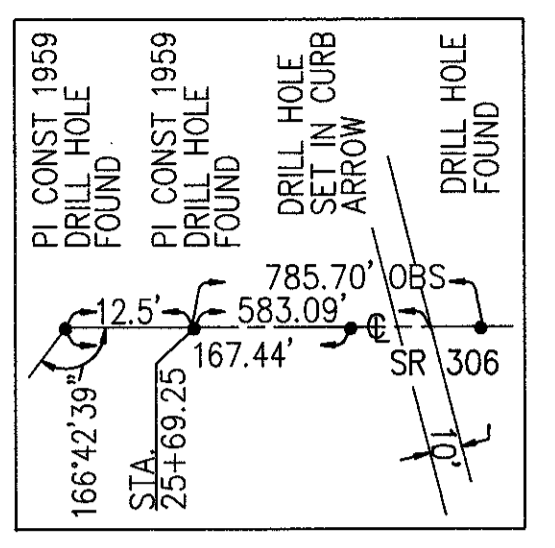

FOR TYPICAL SECTIONS SEE SHEETS . . . 3 & 5
 FOR CROSS SECTIONS SEE SHEETS . . . 33 THRU 35
 FOR PAVEMENT REMOVAL SEE SHEET 41
 FOR STORM SEWER DETAILS SEE SHEET . . . 38
 FOR STORM PROFILE SEE SHEET 34

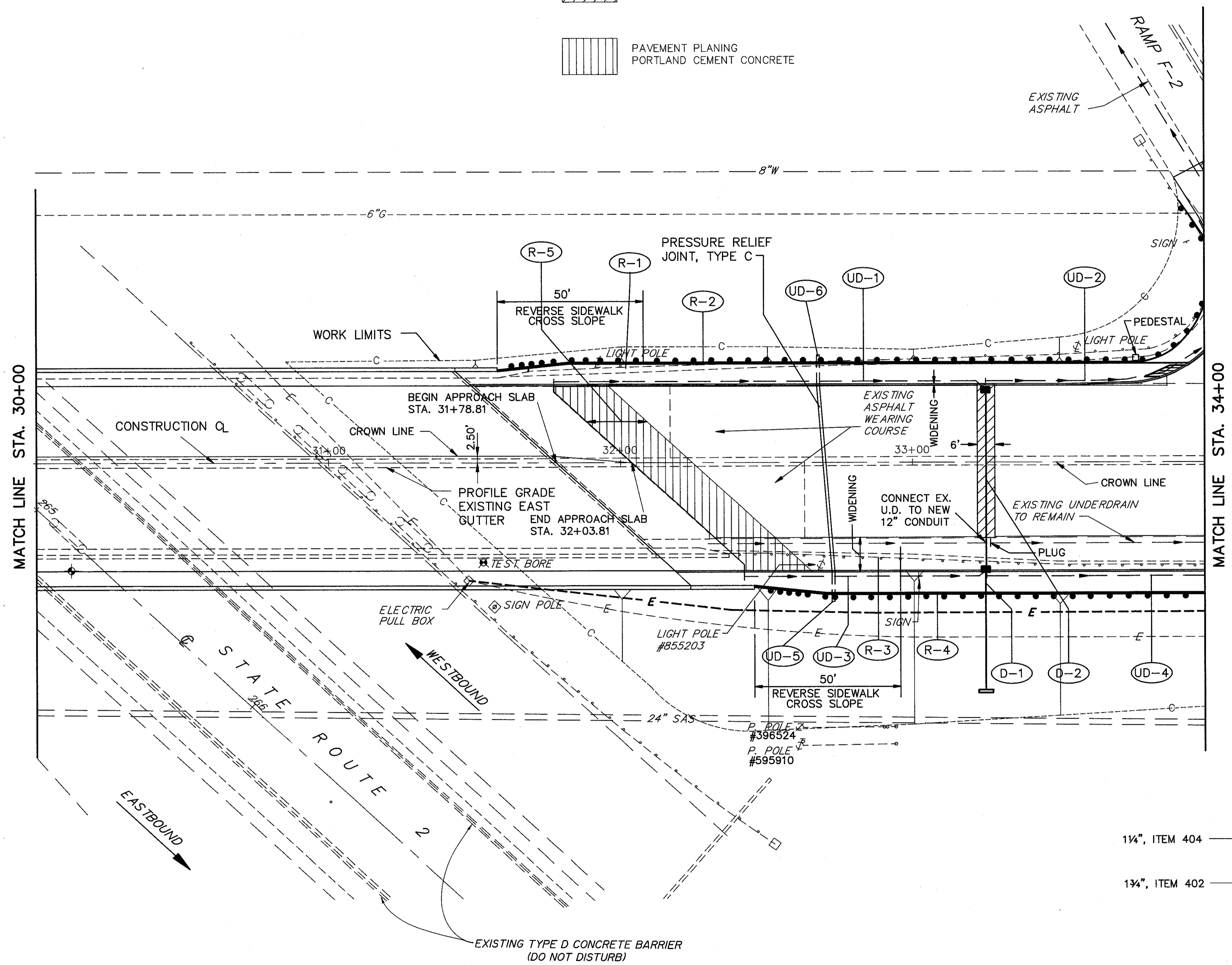

ROADWAY*		202	202	606	606	254	606
REF.	LOCATIONS	EA	LF	LF	EA	S.Y.	EA
R-1	STA. 31+70, 32'LT TO STA. 33+90, 90'LT	1	275				
R-2	STA. 31+55.78, 32'LT. TO STA. 33+90, 90'LT.			275	1		
R-3	STA. 32+35, 32'RT TO STA. 34+00, 36'RT	1	165				
R-4	STA. 32+43.70, 43'RT. TO STA. 34+00, 46'RT.			156			
R-5	STA. 32+03.81 TO STA. 32+23.81					117.8	
TOTALS		2	440	431	1	117.8	1

DRAINAGE*		603	603	604	602
REF.	LOCATIONS	LF	LF	EA	C.Y.
D-1	STA. 33+25, 37'RT TO STA. 33+25, 86'RT	55	1	0.21	
D-2	STA. 33+25, 27'LT TO STA. 33+25, 37'RT	64			
TOTALS		64	55	2	0.21

* QUANTITIES CARRIED TO SUB-SUMMARIES ON SHEET 20.

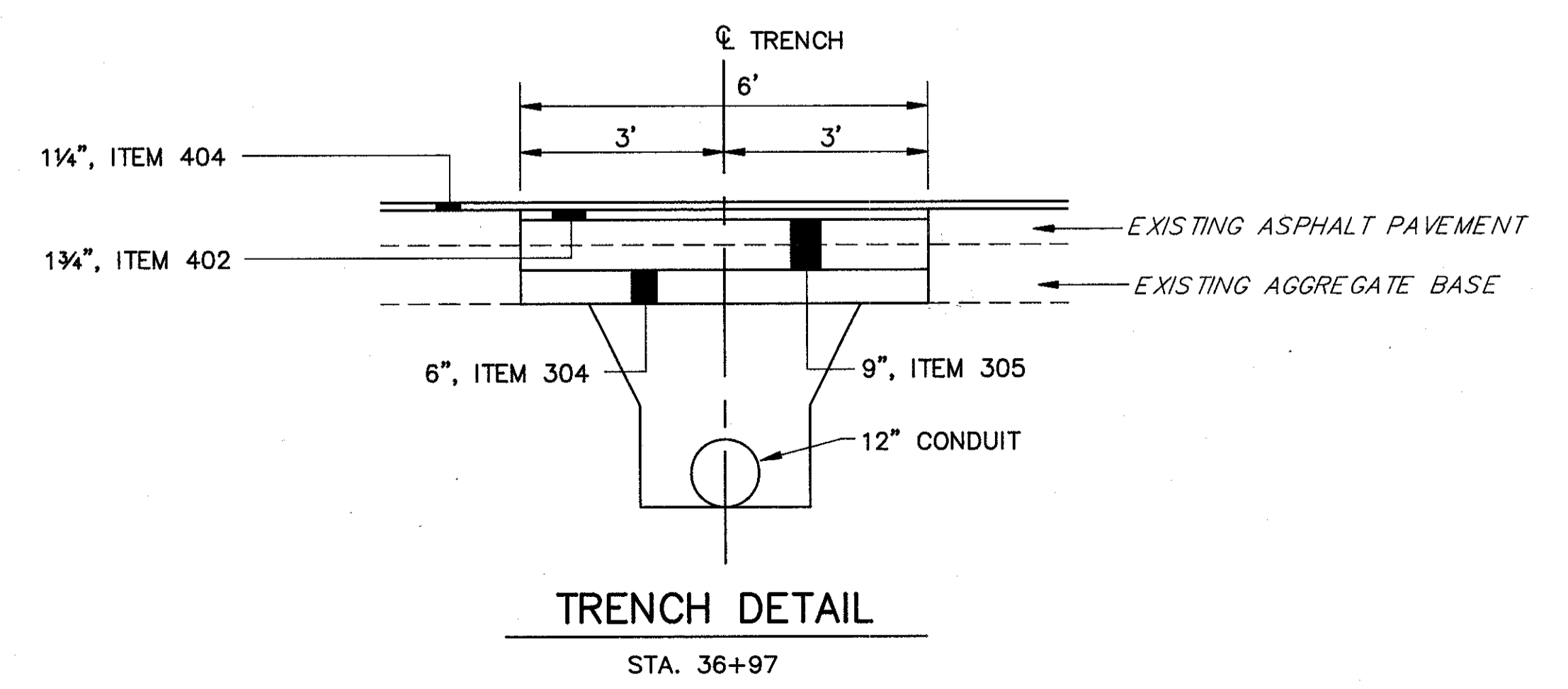

LAK - 306 - 6.82