

TYPICAL SECTIONS

TYPE 404

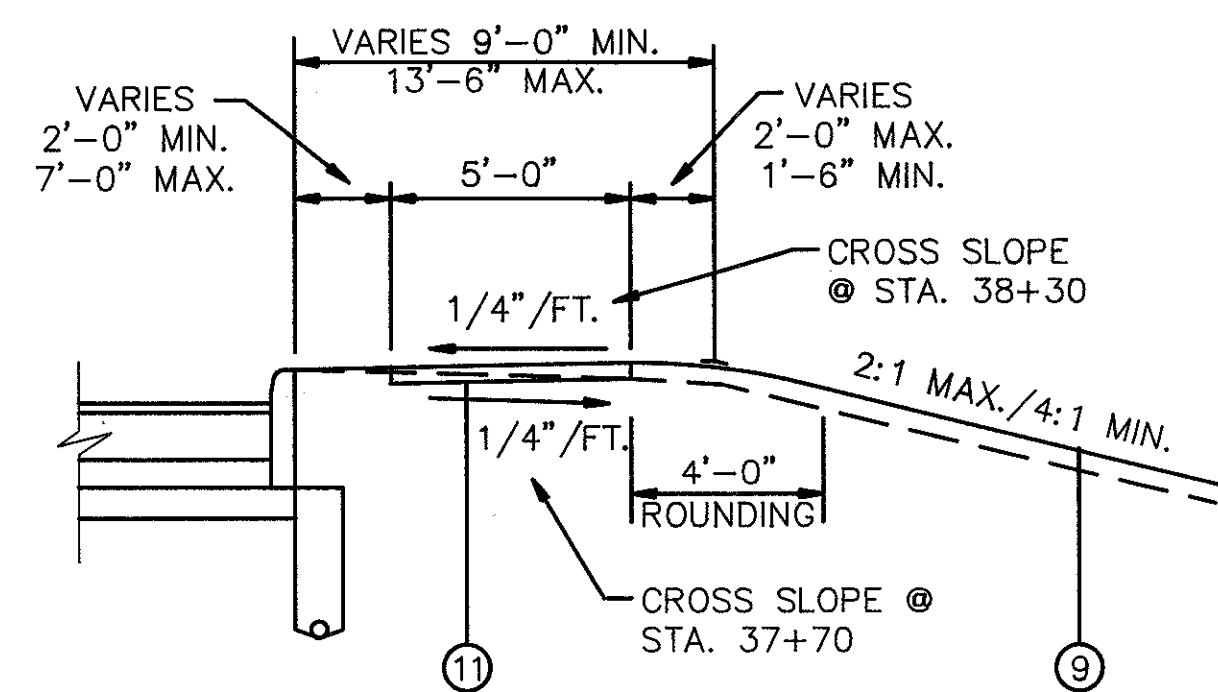

SIDWALK TREATMENT
 STA. 37+70.00 TO STA. 38+30.00
 LEFT & RIGHT

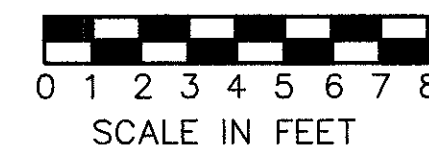
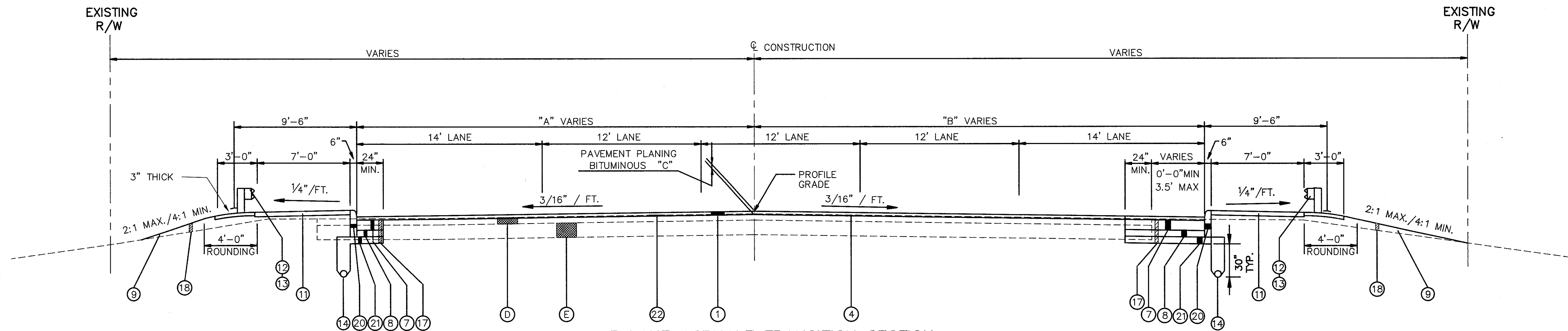

5 LANE ASPHALT TRANSITION SECTION
 STA. 35+50.00 TO STA. 38+30.00 = 280.00 LIN. FT.

"A" VARIES FROM 26.67' AT STA. 35+50.00 TO 28.87' AT STA. 38+30.00
 "B" VARIES FROM 37.33' AT STA. 35+50.00 TO 35.13' AT STA. 38+30.00
 "C" = 0" STA. 35+50.00 TO STA. 37+00.00
 "C" VARIES FROM 0"-1 1/4" STA. 37+00.00 TO STA. 37+25.00
 "C" = 1 1/4" STA. 37+25.00 TO STA. 38+30.00

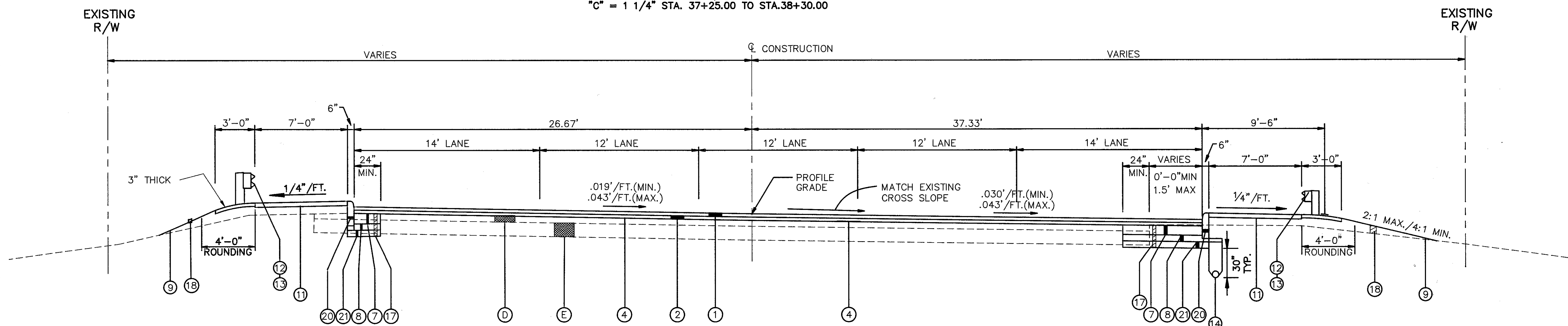

5 LANE ASPHALT TRANSITION SECTION
 STA. 22+35.88 TO STA. 23+25.70 = 89.82 LIN. FT.

SEE SHEET NO.3 FOR LEGEND

TYPICAL SECTIONS