

TRANSVERSE JOINTS

JOINT ASSEMBLY

FED. RD. DIST. NO.	STATE	F.A.G.C. PROJECT	FISCAL YEAR	3-D 50
10	OHIO	F.A.G.M.-70-43	1941	

LAKE COUNTY
S.H. 520 SEC. PAINESVILLE (PT.)
GRADE SEPARATION

NOTES

GENERAL: Expansion joints shown are to be considered as alternates; the type to be used on any project shall be optional with the contractor. The type of joint selected by the contractor and all operations and materials for assembling and installing the joints shall be approved by the engineers.

DOWELS: Prior to placing, the dowels shall be assembled into a unit, as shown hereon, which is to remain in place for expansion, contraction and construction joints. The straight end of each dowel shall be neatly fitted with a metal cap as shown hereon. The straight end of each dowel shall be thoroughly coated, before placing in the pavement, with either bituminous material (see M-5.11 C.C. 2, or heavier, or 600 M grease or equal) the length of the unit shall be not less than the distance between longitudinal joints and sufficient support shall be provided to hold the dowels accurately perpendicular to the joint. When the lane width varies from 11 feet the spacing of the dowels shall be 15 inches and the 6" end spaces shall be equally increased or decreased and shall be less than 10 1/2" but not less than 3".

EXPANSION JOINTS: The spacing of the expansion joints shall not exceed 120 feet. The type and arrangement of expansion joints at intersections will be specifically shown on the plans. The base angle of the dowel assembly and the slope of the expansion joint material shall be as specifically shown on the plans. The filler material in monolithic curbs shall be constructed with the same type of pre-molded filler material as used in the expansion joints.

CONTRACTION JOINTS: Contraction joints shown are to be considered as alternates; the type to be used on any project shall be optional with the contractor, and shall be constructed as shown hereon. Contraction joints shall be spaced so that the length of any slab between transverse joints shall not exceed 60 feet. Joint arrangement at intersections shall be as specifically shown on the plans. The filler material for **PREMOLDED CONTRACTION JOINTS** shall meet the requirements of Sec. M-10.13. The filler material for **3/8" PREMOLDED CONTRACTION JOINTS** shall meet the requirements of Sec. M-10.1 or Supplemental Specifications M-10.12. **IMPRESSED CONTRACTION JOINTS** shall be formed by impressing a device or bar into the newly deposited concrete before initial setting. The device or bar shall be removed as soon as the concrete is in such condition as to prevent distortion or injury to the concrete. The groove so formed shall be of dimensions detailed. After the joint is formed it must be protected from dirt and foreign matter until the joint sealer is poured.

CONSTRUCTION JOINTS: At construction joints the assembled dowel unit shall be reversed so that the straight end of the dowels point in the direction of the concreting operation. This is to permit the rigid bulkhead to be slipped over the straight ends of the dowels. If the construction joint is at an expansion joint the pre-molded expansion joint filler shall be placed to hold the concrete and be backed up by the rigid bulkhead. Care shall be taken in removing the bulkhead and placing the adjacent concrete to see that the dowels are embedded in the concrete without being bent.

PREMOLDED BITUMINOUS FIBER EXPANSION JOINT FILLER: This joint filler material shall meet the requirements of Supplemental Specifications M-10.12. Dowel holes 1/8 inch in diameter shall be accurately punched in the filler material to insure tight fitting dowels. The joint shall at all times be protected from the heat and other agencies which tend to cause distortion. A 12 gage metal cap as shown hereon shall be placed before concreting over the upper edge of each joint filler. This metal cap shall be removed immediately after the finishing machine has passed over the joint. A 3/4" x 1 1/2" strip of planed hardwood or metal shall then be fastened to the pre-molded joint filler to form the 3/4" x 1 1/2" space for the poured joint sealer. Any edging or finishing necessary shall be done along this strip which shall not be removed until the concrete has set. As an alternate method of placing the strip it may be placed before or with the metal cap so that when the cap is removed the strip will be in place. The filler material shall be securely fastened to the 1 inch by 1 inch angle with metal clips and to the 3/8 inch tie rod with No. 10 cap nails. The dowel unit assembled with the filler material shall then be staked rigidly to the subgrade with anchor pins and brace rods or metal shoes as shown hereon.

NON-EXTRUDING BITUMINOUS PREMOLDED JOINT: The filler material shall meet the requirements of Sec. M-10.1. The extrusion chamber plates shall be constructed of 24 gage metal nailed to the section. When assembled in the field a template and protected bench shall be provided for the workmen to insure accuracy in assembling. Dowel holes shall be punched in the filler material and shall be 1/8 inch round holes to insure tight fitting dowels. Dowel holes in the side plates shall be 3/8 inch in diameter. In no case shall dowels interfere with the extrusion chambers. At each edge of the pavement the extrusion chambers shall be bent down to seal the ends of the chambers. The joint shall at all times be protected from heat and other agencies which tend to cause distortion. The assembled joint shall be secured together by 1/2 inch stove bolts or other approved fasteners. The holes for the fasteners may be made in the factory; when made in the field they shall be drilled after the joint is assembled. The stove bolts shall be fastened with thin nuts, speed nuts, or rubber tubing screwed on. In order for this joint to function properly the plates must be fitted snugly against the filler material and held in position while concrete is being deposited so that no mortar enters between the plates and filler, after which the fasteners must function in such a manner as will permit the plates to move with the concrete slab. The use of clinched nails or any such fasteners as would prevent the movement of the plates will not be permitted. The dowel unit assembled with the filler and plates shall then be staked rigidly to the subgrade with anchor pins and brace rods or metal shoes as shown hereon.

SELF EXPANDING CORK JOINT: The filler material for this joint shall meet the requirements of Supplemental Specification M-10.14, and shall be accurately held in place by without special fasteners. **PREMOLDED BITUMINOUS FIBER EXPANSION JOINT FILLER.**

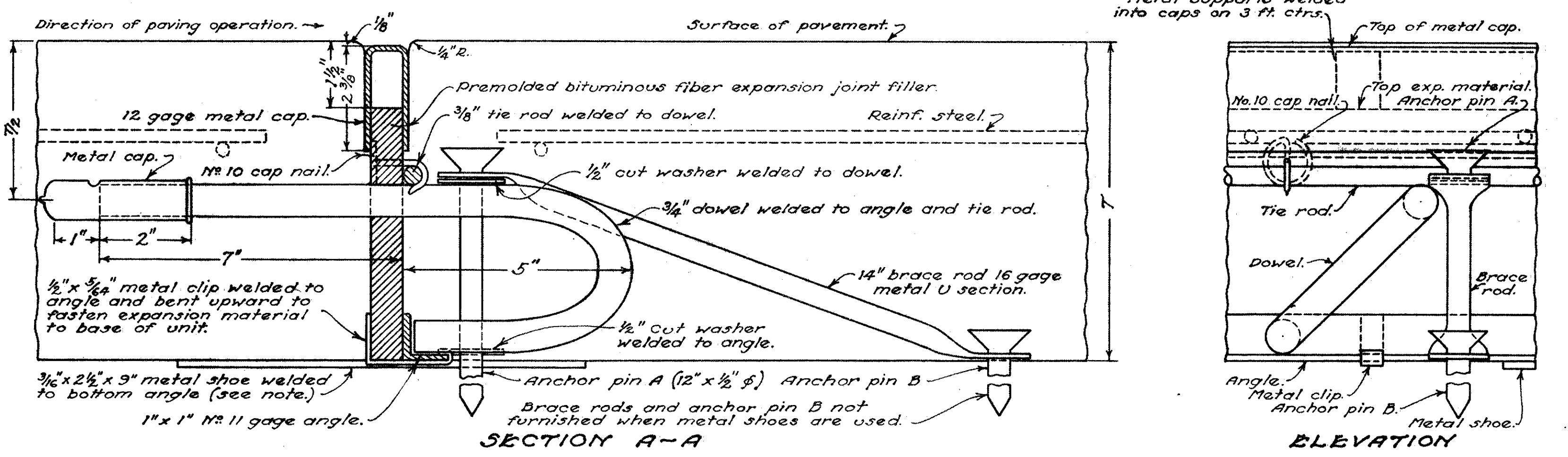
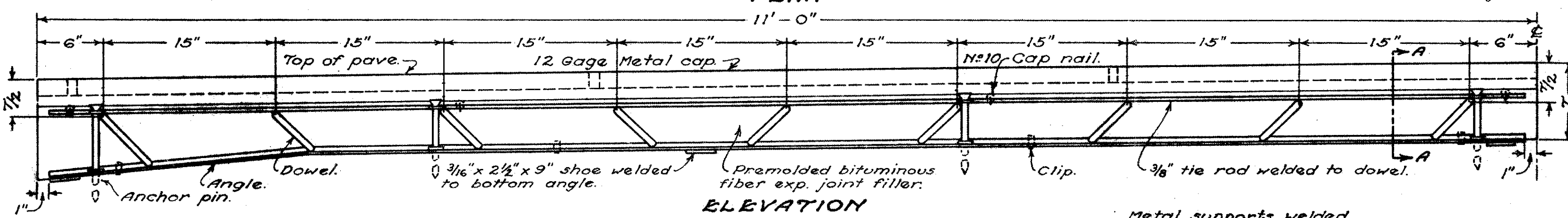
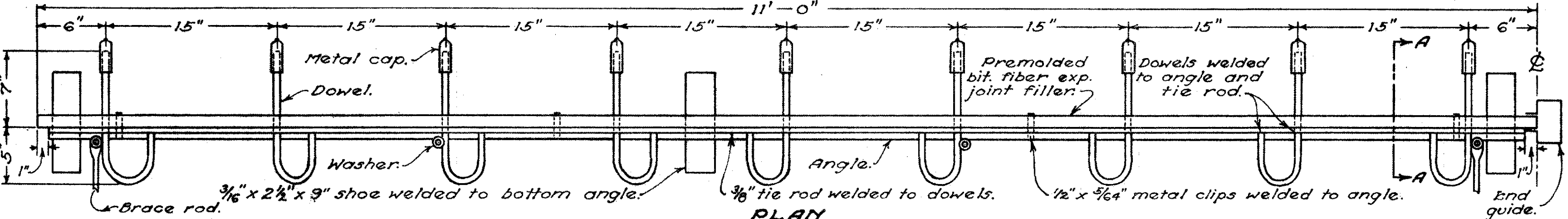

CONTRACTION JOINTS

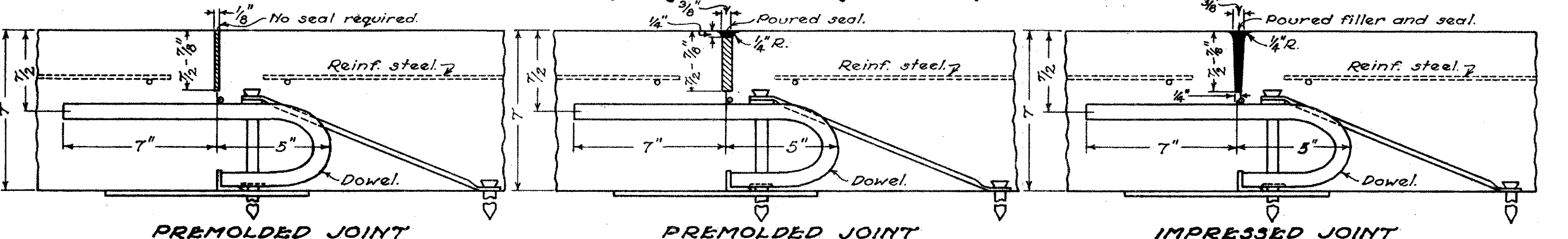

CONSTRUCTION JOINT

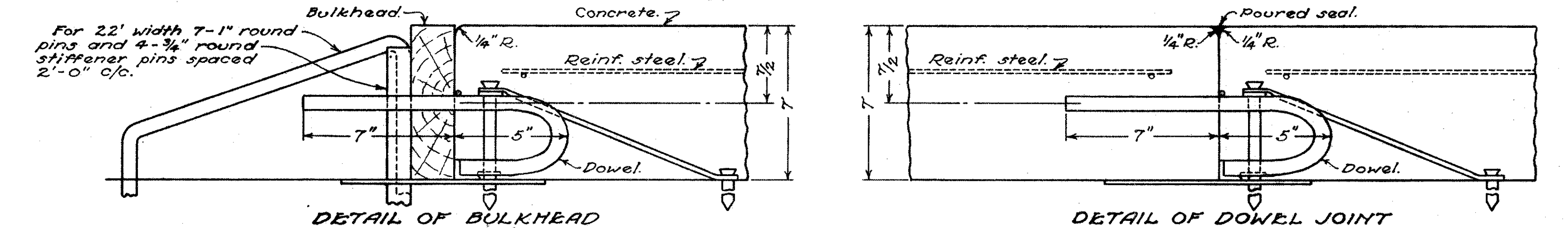

NOTES

TREATMENT OF EXPANSION JOINTS AT LONGITUDINAL JOINTS: At the junction of longitudinal and transverse joints a positive method shall be used to connect the joints and maintain the vertical and longitudinal alignment of the two joints. Longitudinal keys and keyways where used, shall be omitted for the thickness of the joint.

EDGING JOINTS: Special care shall be exercised in edging joints so that the width of the opening does not exceed that shown.

JOINT SEALER: Material for sealing expansion, contraction and construction joints in pavements where Non-Extruding Bituminous Premolded Filler or Self Expanding Cork Filler is used shall meet the requirements of Section M-5.4 F-1 for liquid bituminous seal. Immediately before placing liquid bituminous seal an application of kerosene shall be applied by pressure spray brush or swab to the joint to be in contact with the seal. Material for sealing expansion, contraction and construction joints in pavements where Premolded Bituminous Fiber expansion joint filler is used shall meet the requirements of Supplemental Specification M-10.23 for poured joint filler.

CONSTRUCTION DETAILS: The assembled unit shall be rigidly held in such position as will keep the plane of the dowels parallel to the surface of the pavement and the expansion joint material at right angles to the pavement surface. This shall be accomplished by staking the unit to the subgrade with a sufficient number of anchor pins "A" and by bracing with a sufficient number of brace rods and anchor pins "B". Not less than four "A" pins, two brace rods and "B" pins shall be used for each eleven foot section. Anchor pins 18" long shall be used where necessary to hold the unit in position. The metal shoes may be used in lieu of brace rods where hard shale or rock subgrade is encountered.

The metal cap shall fit closely on the dowel so that when forced on it can not easily be displaced. It shall be crimped to receive only two inches of the dowel and leave one inch space in the end for future movement of the dowel. It shall be made to prevent mortar from entering any part of it when in place on the dowel.

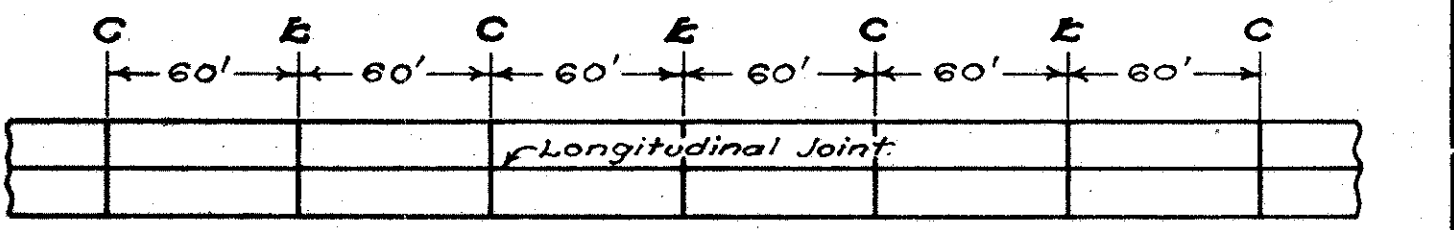

ARRANGEMENT OF TRANSVERSE JOINTS
C = Contraction Joint
E = Expansion Joint

END GUIDE

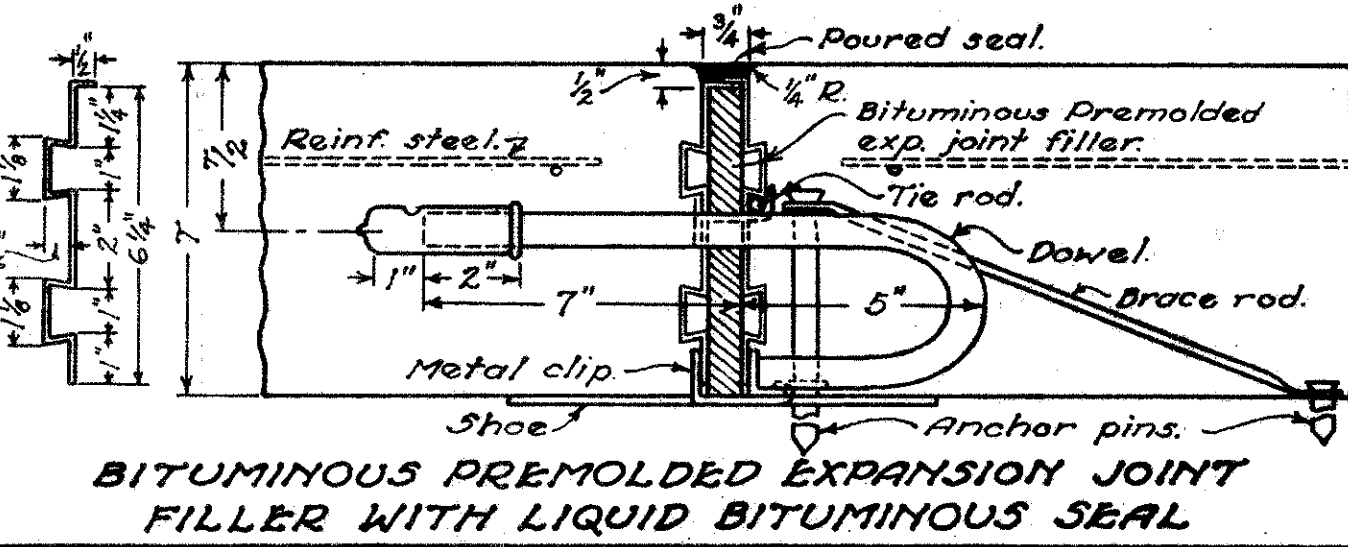
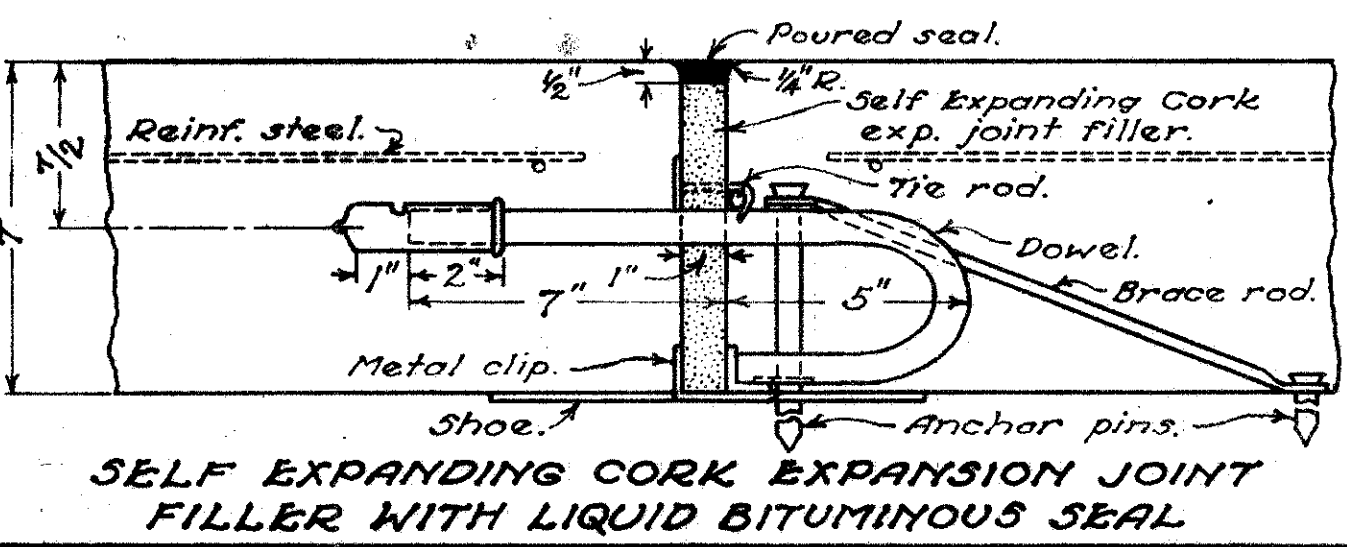
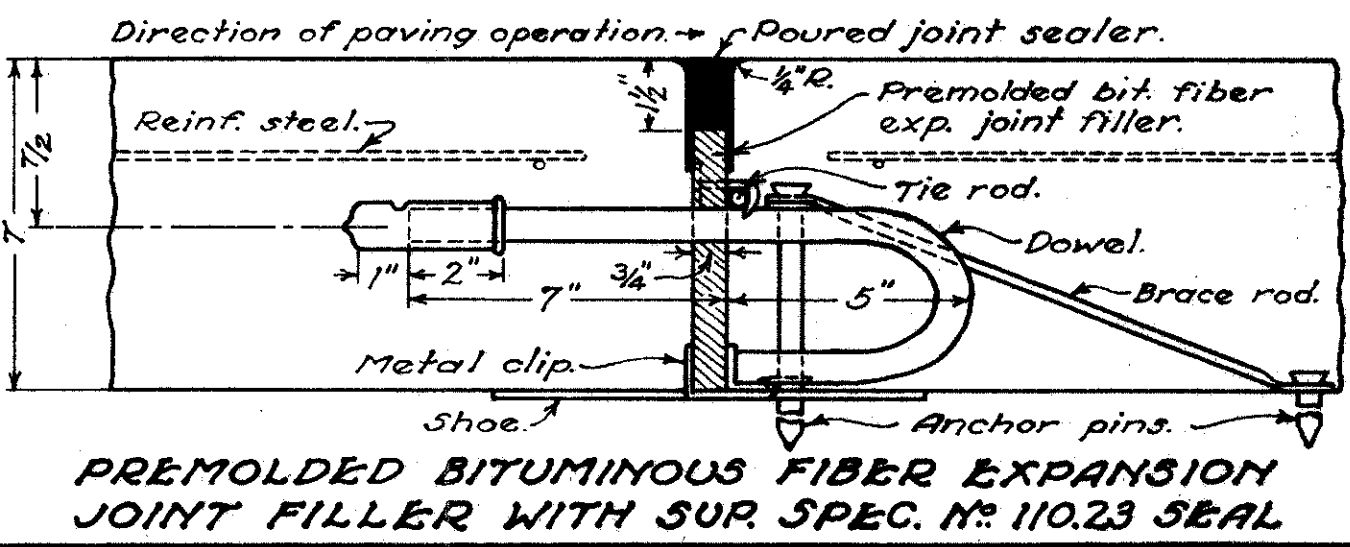
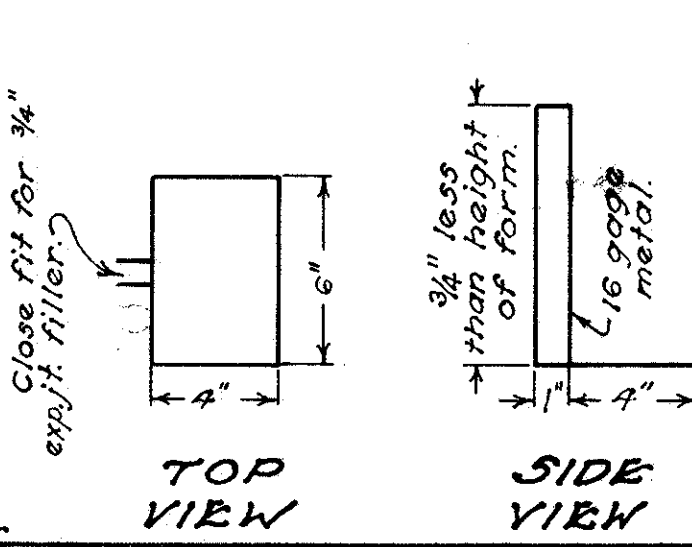

TJ-9

DATE
7-1-40
8-1-40