

MICROFILMED  
JAN 29 1986

B.M. TOP OF TOP NUT, HYDRANT  
STA. 11+98, 28' LEFT  
ELEVATION=100.00

SHEET NO.	DATE	PROJECT	FOUNDED
2	CHIC		

4  
10

LAKE COUNTY  
LAK-20-18.07

PLAN NO. BR-103-02

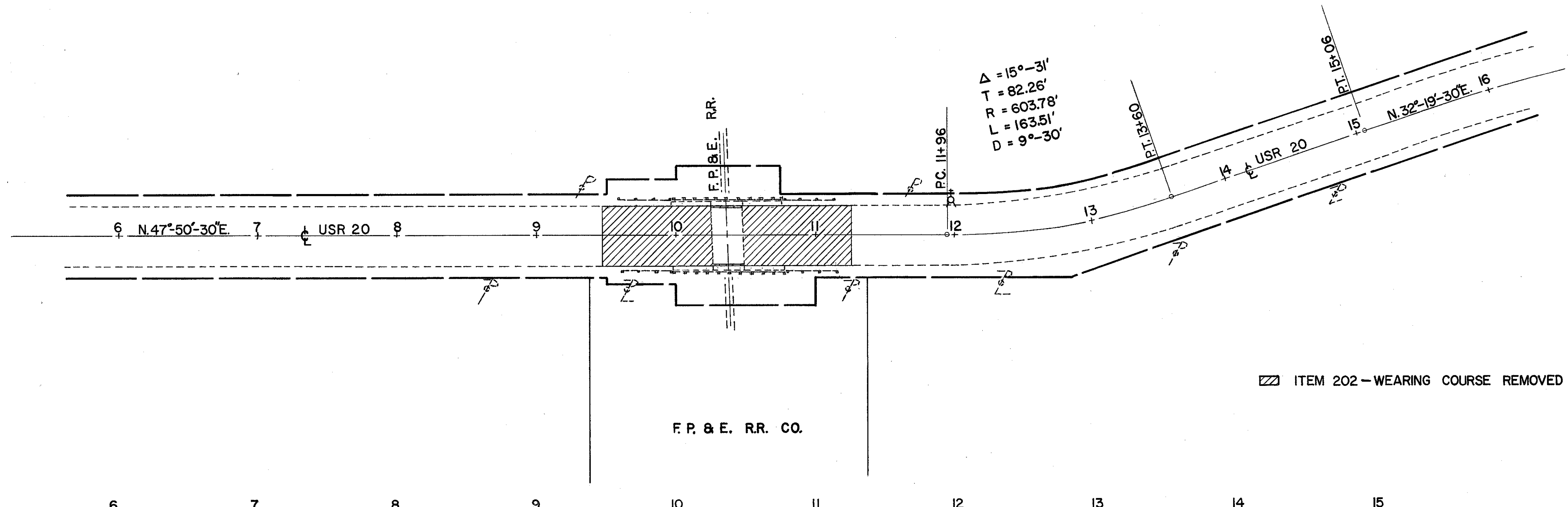
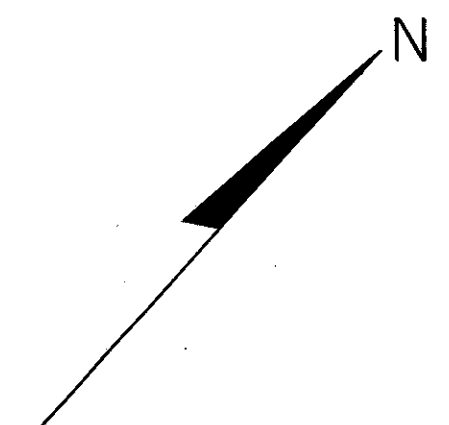

▨ ITEM 202 - WEARING COURSE REMOVED

F. P. & E. R.R. CO.

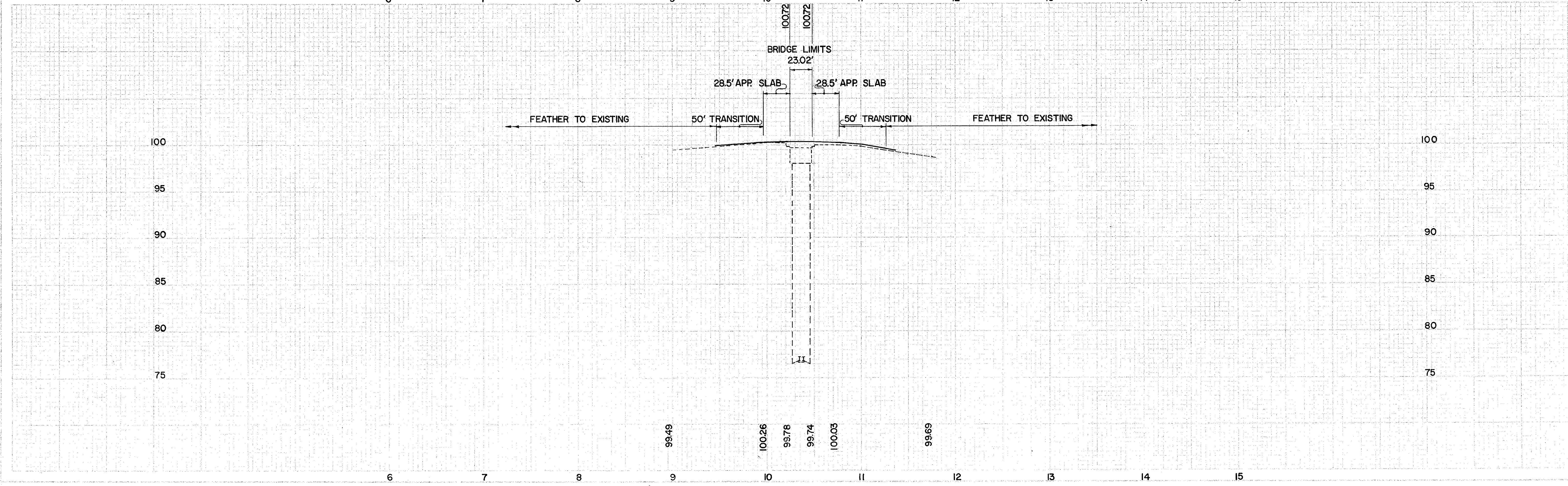

PLAN & PROFILE STA. 6+00 TO STA. 15+00