

LAKE COUNTY  
LAK-2-7.39

ST. Sta. 422+53.48 Const. C. Bk. =  
Sta. 422+55.03 Survey B. An.

C.S. Sta. 419+53.48

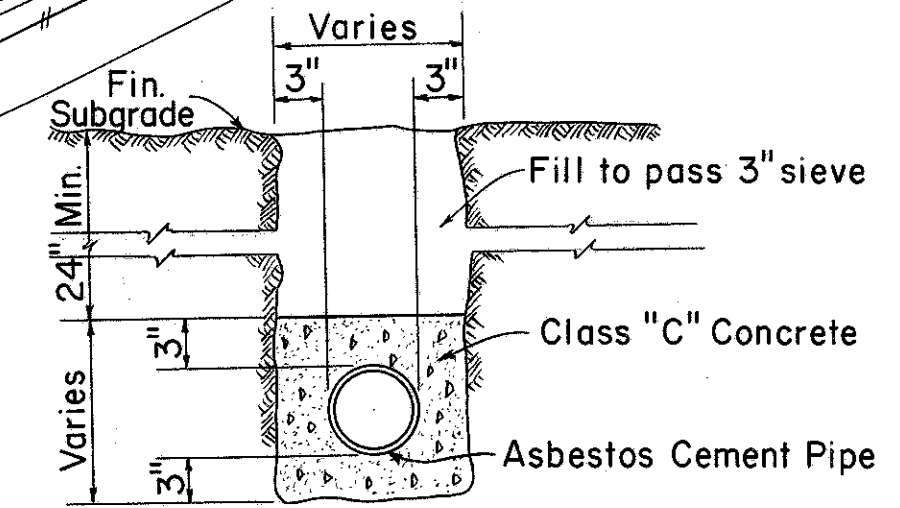
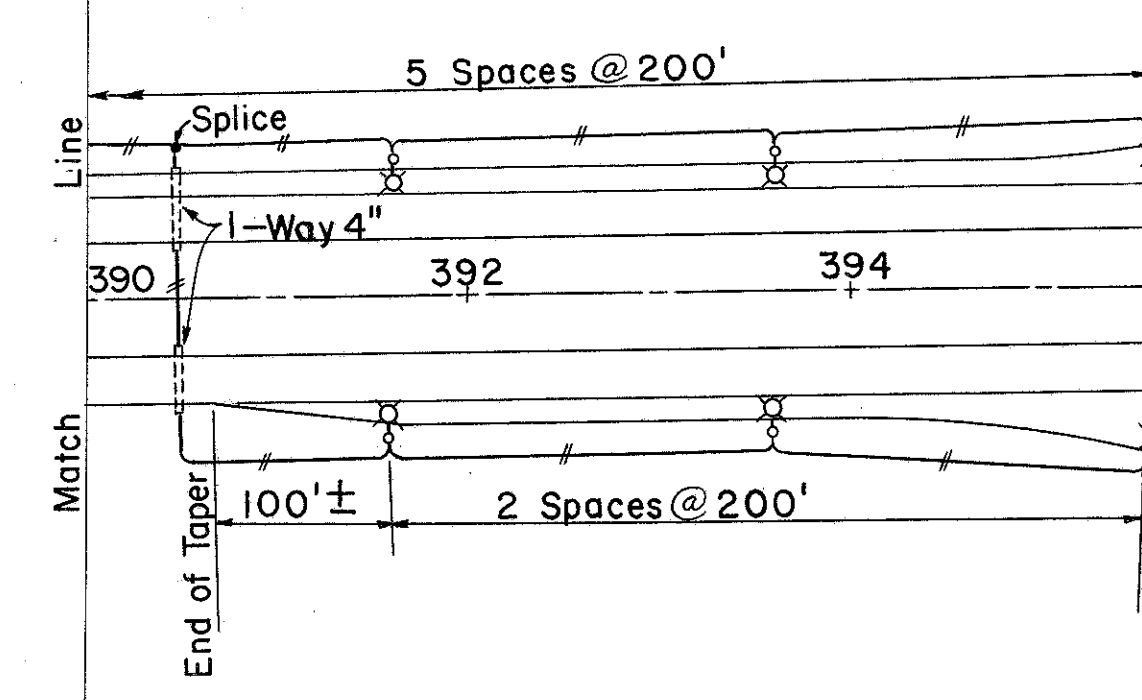
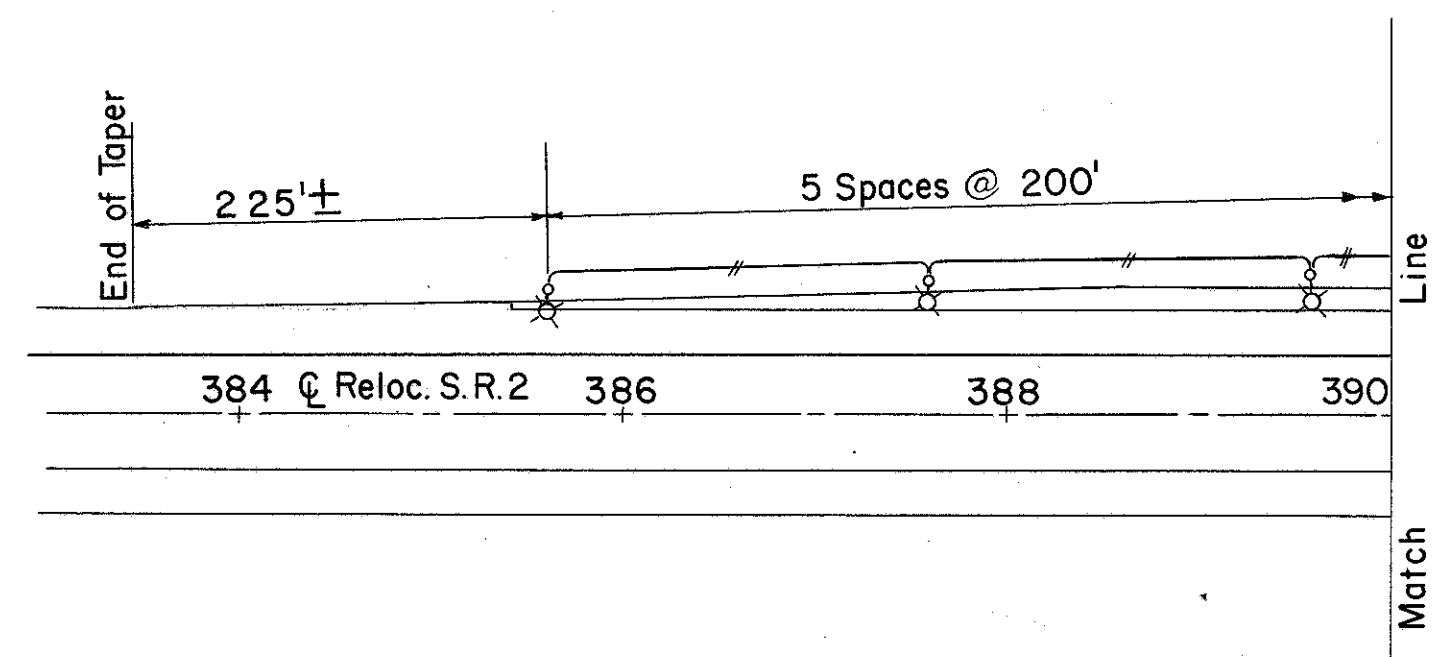
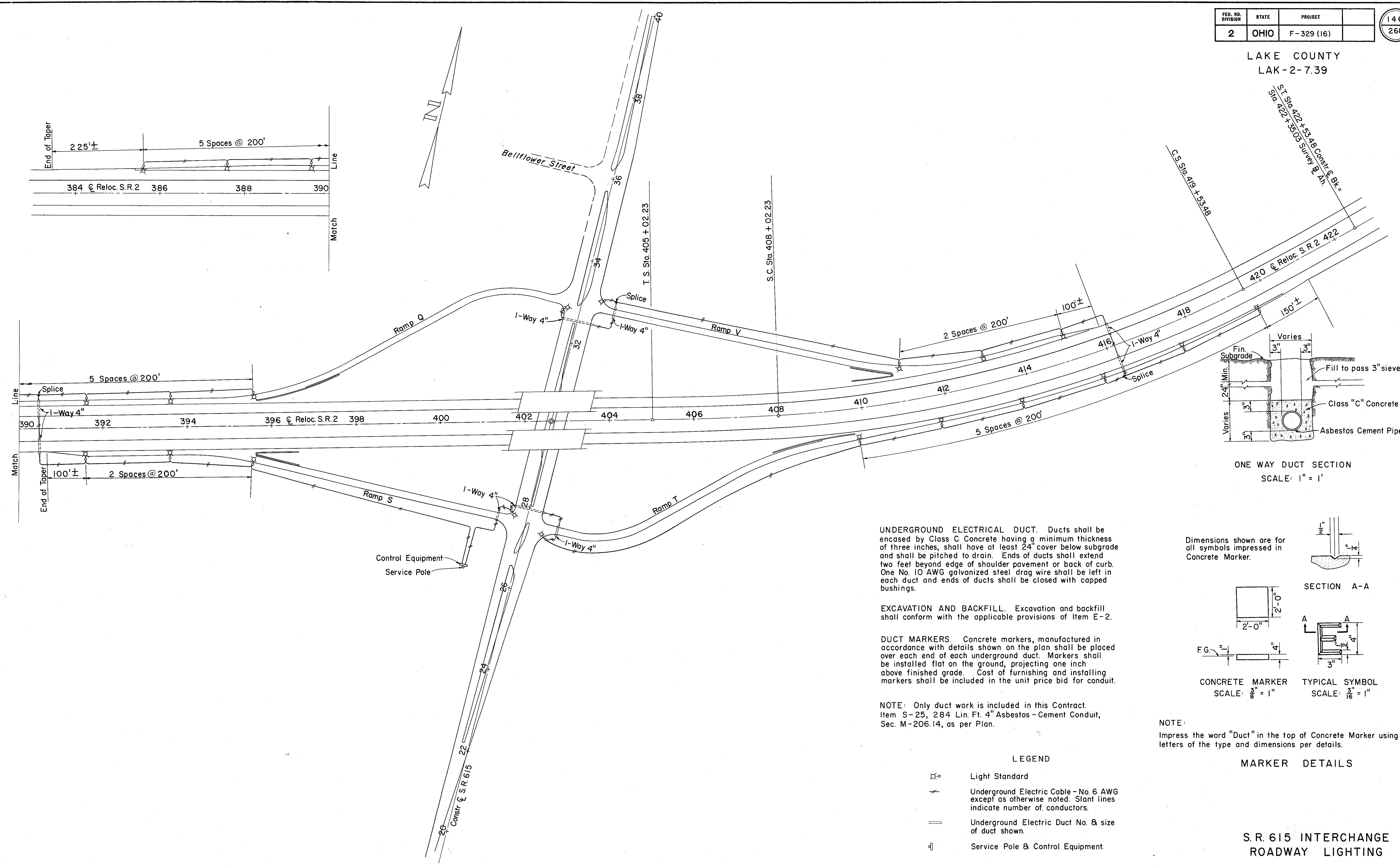

**UNDERGROUND ELECTRICAL DUCT.** Ducts shall be encased by Class C Concrete having a minimum thickness of three inches, shall have at least 24" cover below subgrade and shall be pitched to drain. Ends of ducts shall extend two feet beyond edge of shoulder pavement or back of curb. One No. 10 AWG galvanized steel drag wire shall be left in each duct and ends of ducts shall be closed with capped bushings.

**EXCAVATION AND BACKFILL.** Excavation and backfill shall conform with the applicable provisions of Item E-2.

**DUCT MARKERS.** Concrete markers, manufactured in accordance with details shown on the plan shall be placed over each end of each underground duct. Markers shall be installed flat on the ground, projecting one inch above finished grade. Cost of furnishing and installing markers shall be included in the unit price bid for conduit.

**NOTE:** Only duct work is included in this Contract. Item S-25, 284 Lin. Ft. 4" Asbestos-Cement Conduit, Sec. M-206.14, as per Plan.

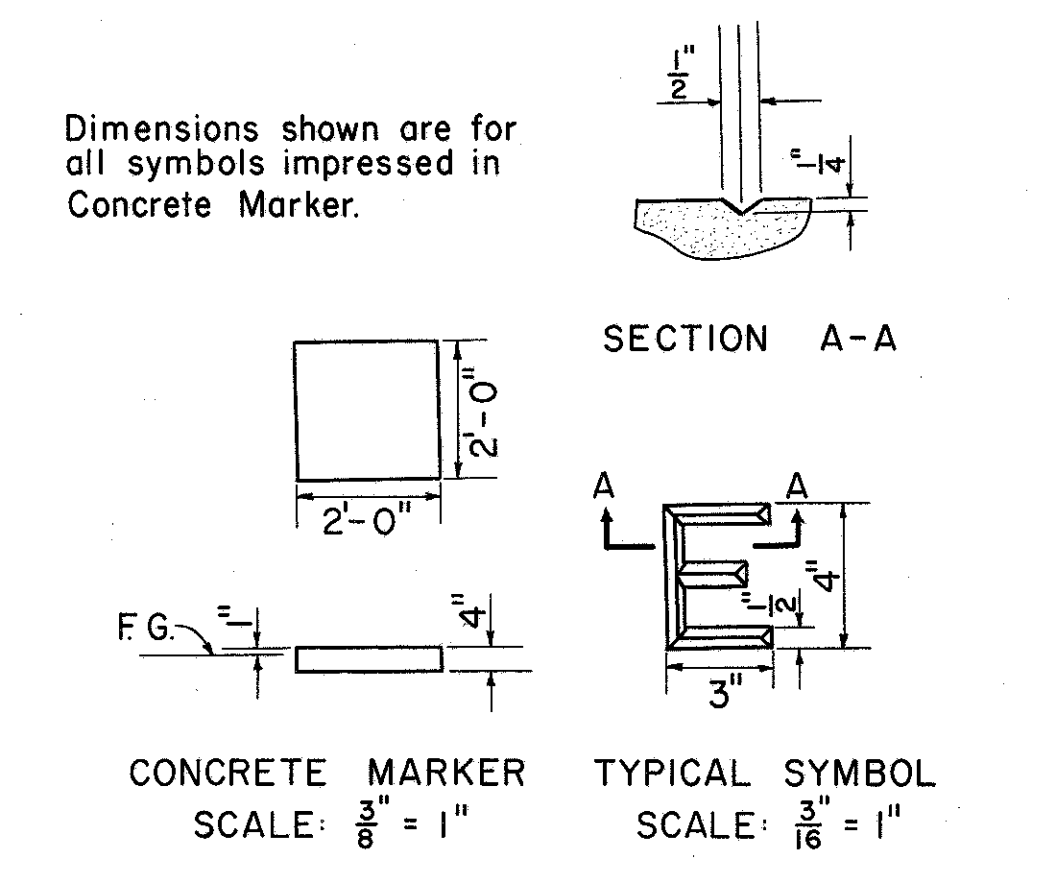

**NOTE:** Impress the word "Duct" in the top of Concrete Marker using letters of the type and dimensions per details.

- LEGEND**
- ⊗ Light Standard
  - Underground Electric Cable - No. 6 AWG except as otherwise noted. Slant lines indicate number of conductors.
  - Underground Electric Duct No. & size of duct shown.
  - ⊥ Service Pole & Control Equipment.

**S. R. 615 INTERCHANGE  
ROADWAY LIGHTING**