

RAMP A
CURVE DATA
P.I. Sta. 0+52.37
 $\Delta = 8^\circ 21' 52.9''$ Lt.
D = 8° 00' 00"
R = 716.20'
L = 104.56'
T = 52.37'

RAMP A
CURVE DATA
P.I. Sta. 1+89.00
 $\Delta = 40^\circ 19' 13.36''$ Lt.
R = 230.00'
L = 161.86'
T = 84.44'

RELOC. C.
S.R. 2
CURVE DATA
P.I. Sta. 179 + 39.38
 $\Delta = 28^\circ 00' 00''$ Rt.
D = 1° 15' 00"
R = 4583.66'
L = 2240.00'
T = 1142.84'

CONSTRUCTION JOINT LEGEND

- ① Standard Longitudinal Joint
- ② Standard Expansion Joint
- ③ Standard Key Joint without Tie Bars
- ④ Expansion Joint without Dowels

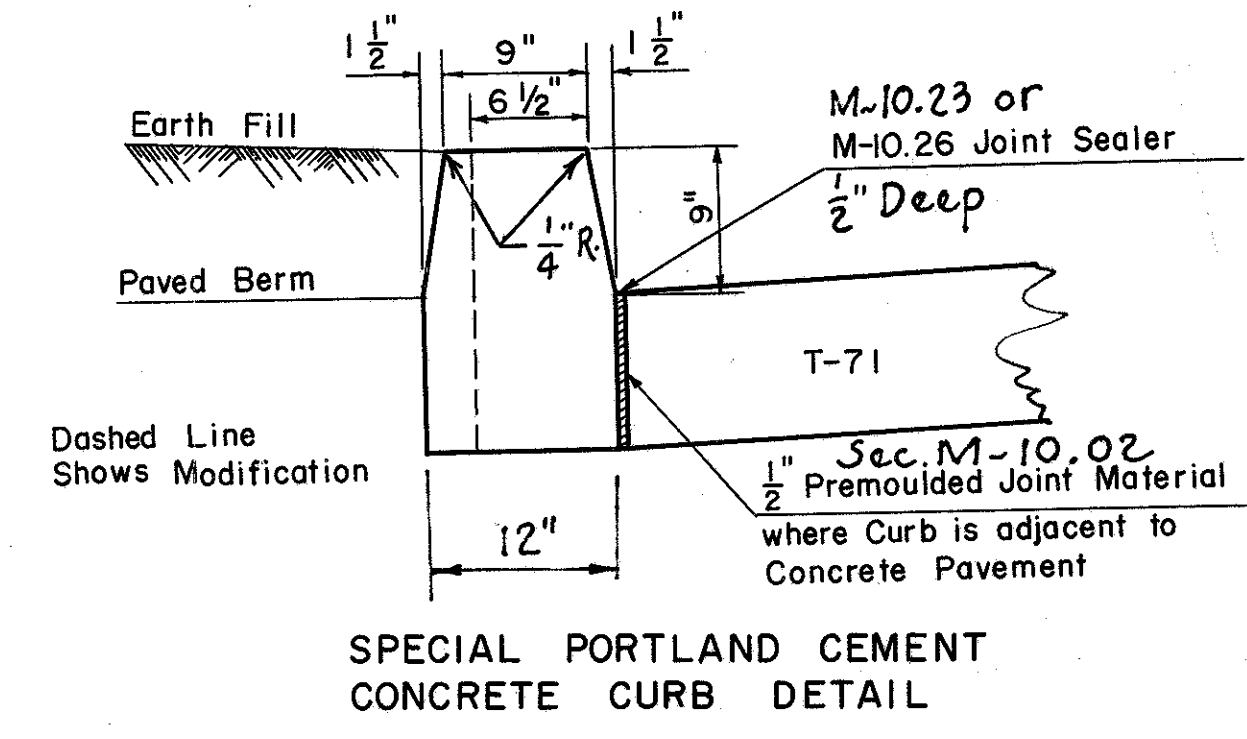

RAMP A ENTRANCE TERMINAL

RAMP A EXIT TERMINAL

RAMP A
CURVE DATA
P.I. Sta. 10+86.16
 $\Delta = 3^\circ 41' 52.34''$ Lt.
D = 2° 00' 00"
R = 2864.73'
L = 184.89'
T = 92.48'

CONSTR. C.
LOST NATION RD.
CURVE DATA
P.I. Sta. 35 + 97.31
 $\Delta = 8^\circ 42' 15''$ Rt.
D = 2° 00' 00"
R = 2864.79'
L = 435.21'
T = 218.02'

CONSTR. C.
LOST NATION RD.
SPIRAL DATA
P.I. Sta. 33 + 29.29
 $\theta_s = 1^\circ 30' 00''$ Rt.
L_s = 150'
L.T. = 100'
S.T. = 50'

CONSTR. C.
LOST NATION RD.
P.I. Sta. 38 + 64.50
 $\theta_s = 1^\circ 30' 00''$ Rt.
L_s = 150'
L.T. = 100'
S.T. = 50'
7' Rad. to Face of Curb

LOST NATION ROAD INTERCHANGE
RAMP A
Scale 1" = 20'-0"