

j:\LAK\13486\bridge\LAK002\_0400C\sheets\002\_0400CSD016.dgn 03-JUL-2008 1:47PM intn

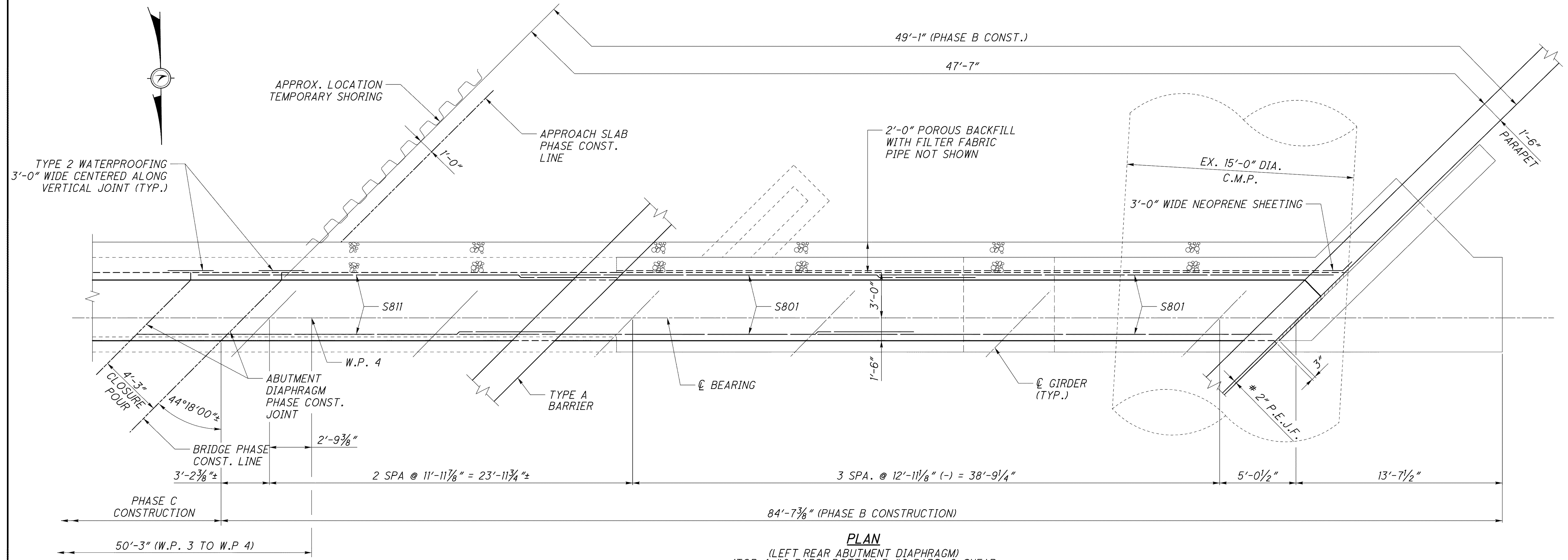

**PLAN**  
(LEFT REAR ABUTMENT DIAPHRAGM)  
(TOP 4-#8 BARS, BOTTOM 5-#8 BARS, & SHEAR REINFORCING NOT SHOWN FOR CLARITY)

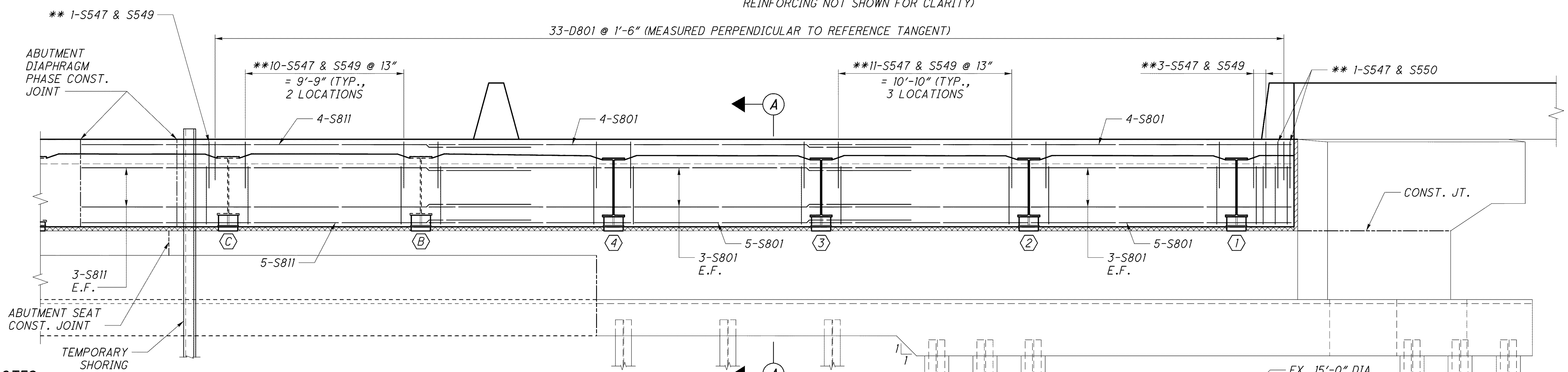

**ELEVATION**  
(LEFT REAR ABUTMENT DIAPHRAGM)

**NOTES**

1. FOR REMOVAL DETAILS, SEE SHEET 14/67 AND 16/67.
2. MINIMUM BAR LAPS: #8 BAR = 69".
3. FOR SECTION A-A, SEE SHEET 57/67.
4. FOR PHASE C CONSTRUCTION OF LEFT REAR ABUTMENT DIAPHRAGM, SEE SHEET 48/67.
5. FOR ADDITIONAL NOTES, SEE SHEET 55/67.
6. FOR LIST OF ABBREVIATIONS, SEE SHEET 4/67.
7. ALL PHASES REFERENCED ARE TO BE COMPLETED UNDER STAGE 3 SEQUENCE OF CONSTRUCTION, SEE MOT DRAWINGS.

**LEGEND**

\*\* BARS PLACED PARALLEL TO CL OF GIRDERS AND SPACING MEASURED ALONG CL OF ABUTMENT  
# COST INCLUDED WITH SUBSTRUCTURE CONCRETE FOR PAYMENT.

