

**LEGEND**

\*\* BARS PLACED PARALLEL TO ∅ OF GIRDERS AND SPACING MEASURED ALONG ∅ OF ABUTMENT

# COST INCLUDED WITH SUBSTRUCTURE CONCRETE FOR PAYMENT.

**PLAN**  
(RIGHT REAR ABUTMENT DIAPHRAGM)  
(TOP 4-#8 BARS, BOTTOM 5-#8 BARS, & SHEAR REINFORCING NOT SHOWN FOR CLARITY)

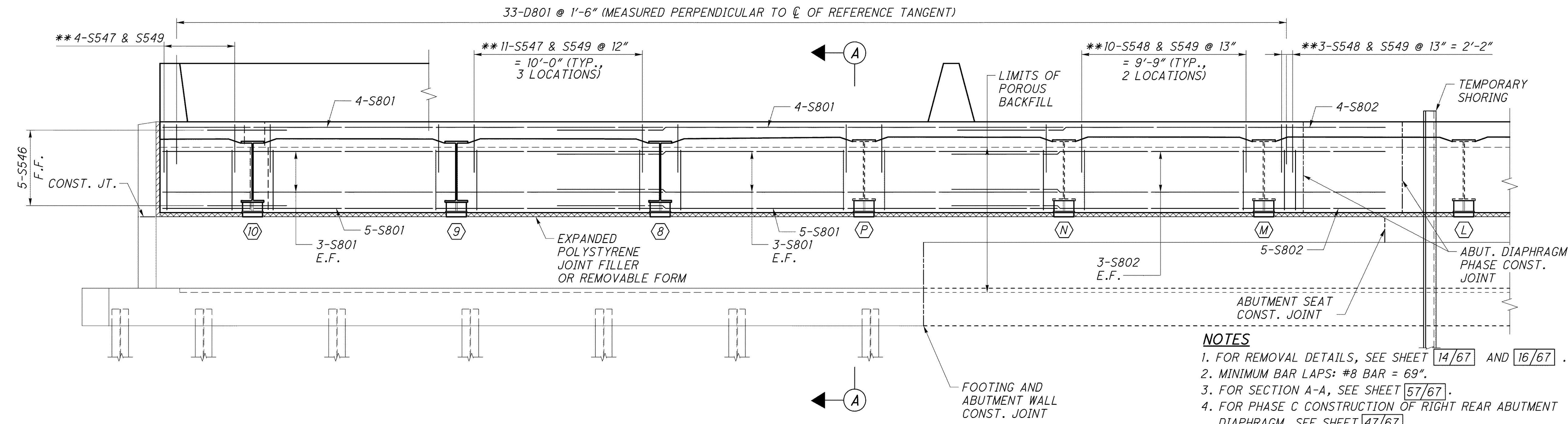

**ELEVATION**  
(RIGHT REAR ABUTMENT DIAPHRAGM)

- NOTES**
1. FOR REMOVAL DETAILS, SEE SHEET 14/67 AND 16/67.
  2. MINIMUM BAR LAPS: #8 BAR = 69".
  3. FOR SECTION A-A, SEE SHEET 57/67.
  4. FOR PHASE C CONSTRUCTION OF RIGHT REAR ABUTMENT DIAPHRAGM, SEE SHEET 47/67.
  5. FOR ADDITIONAL NOTES, SEE SHEET 55/67.
  6. FOR LIST OF ABBREVIATIONS, SEE SHEET 4/67.
  7. ALL PHASES REFERENCED ARE TO BE COMPLETED UNDER STAGE 3 SEQUENCE OF CONSTRUCTION, SEE MOT DRAWINGS.

j:\LAK\13486\bridge\LAK002\_0400C\sheets\02\_0400CSD013.dgn 03-JUL-2008 1:46PM lintn

DESIGNED	BMG	CHECKED	PWP
DRAWN	NAL	REVISED	
REVIEWED	RJO	STRUCTURE FILE NUMBER	4300572(L) 4300602(R)
DATE	6-19-08		