

\\Akrn01\Data\Civil\2004108\00\13486\signals\sheets\13486CPSOM01.dgn 6/16/2008 9:21:40 AM svarrecchia

LEGEND

- PROPOSED MAST ARM SUPPORT POLE AND FOUNDATION
- PROPOSED PEDESTAL WITH PEDESTRIAN SIGNAL HEAD AND PUSHBUTTON
- PROPOSED VEHICULAR SIGNAL HEAD
- PROPOSED TRAFFIC SIGNAL CONTROLLER WITH WORKPAD
- PROPOSED PULL BOX
- PROPOSED PREEMPTION CONFORMATION LIGHT AND RECEIVER
- PROPOSED CONDUIT (725.04)
- PROPOSED SIGN
- VIDEO DETECTION ZONE
- VIDEO DETECTION CAMERA

FOR INTERCONNECT PLANS,  
SEE SHEET 1176

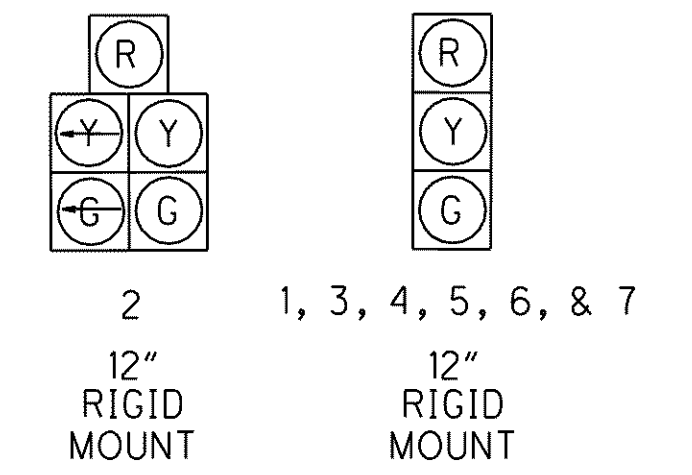
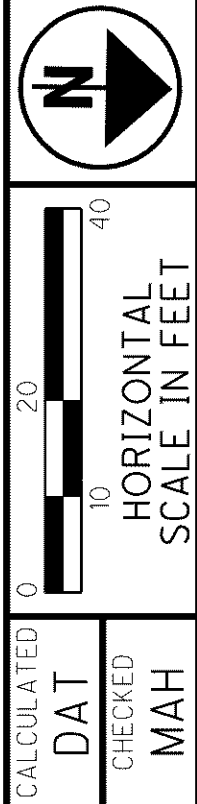

SIGNAL INDICATIONS

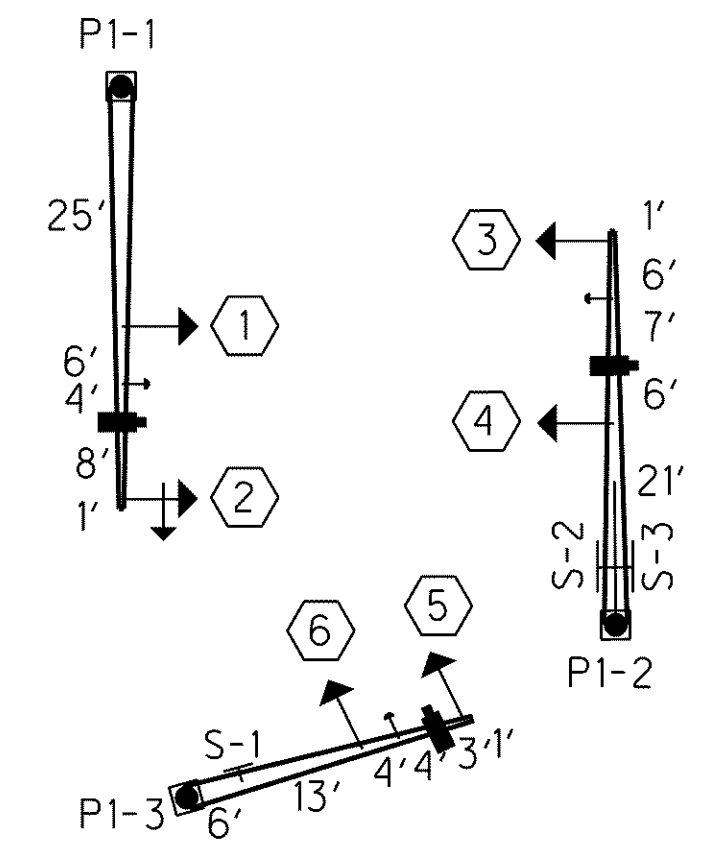

MAST ARM DIAGRAM

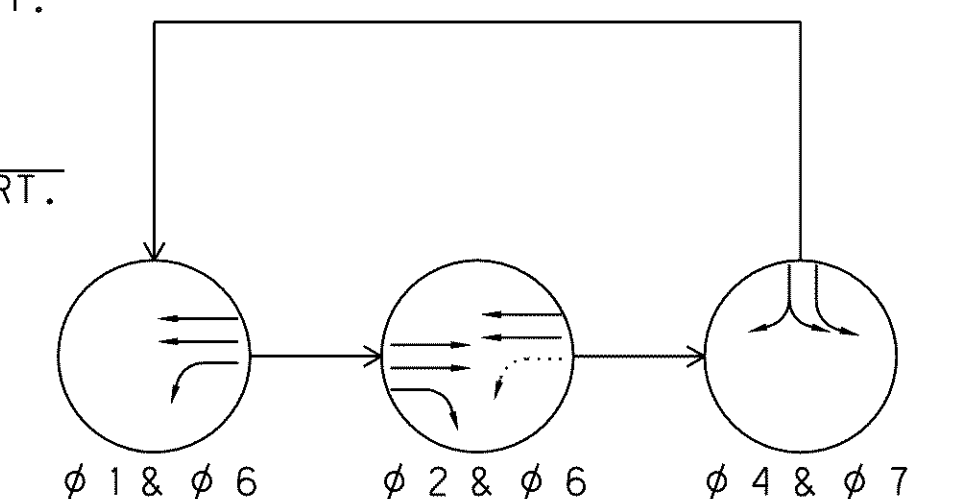
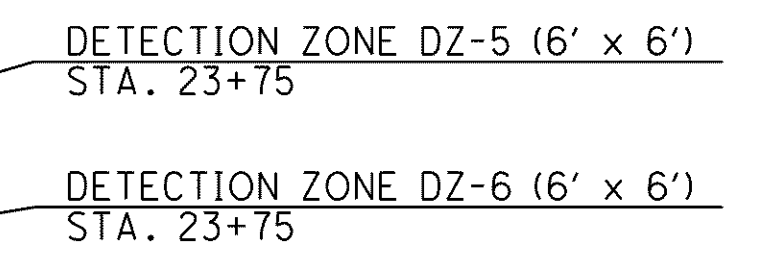

PHASING DIAGRAM

TRAFFIC SIGNAL PLAN  
SOM CENTER RD / RAMP B / RAMP C INTERSECTION

LAK-2-3.32  
1167  
1679

