

Boundary Survey & Lot Split

For: Heisley Point, LLC

Situated in the City of Mentor, County of Lake and State of Ohio
and known as being part of Original Merry Lot, Tract 6.

January 2018 SCALE 1"=30'
Revised April 2018

CERTIFICATION

I hereby certify that this plat was prepared from a field survey made under my direct supervision. Monuments were found or set as indicated. Dimensions are expressed in feet and decimal parts thereof. Bearings are based on NAD 83 GEOID 12B ODOT VRS Network. All of which are correct to the best of my knowledge and belief. This plat was prepared in accordance with the provisions of Chapter 4733-37 of the Ohio Administrative Code. This plat was prepared without the benefit of an abstract of title and is subject to any state of facts revealed by an examination of the same.

James R. Pegoraro Jr.
James R. Pegoraro Jr., P.S. #8150

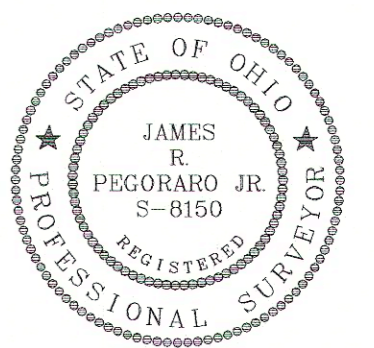

SURVEY ACREAGES

- Overall Survey: 3.4304 Ac. (149,430 sq.ft.) to Original RW
- Split: 1.1975 Ac. (52,164 sq.ft.) to R/W
- Remainder: 2.2329 Ac. (97,266 sq.ft.) to R/W

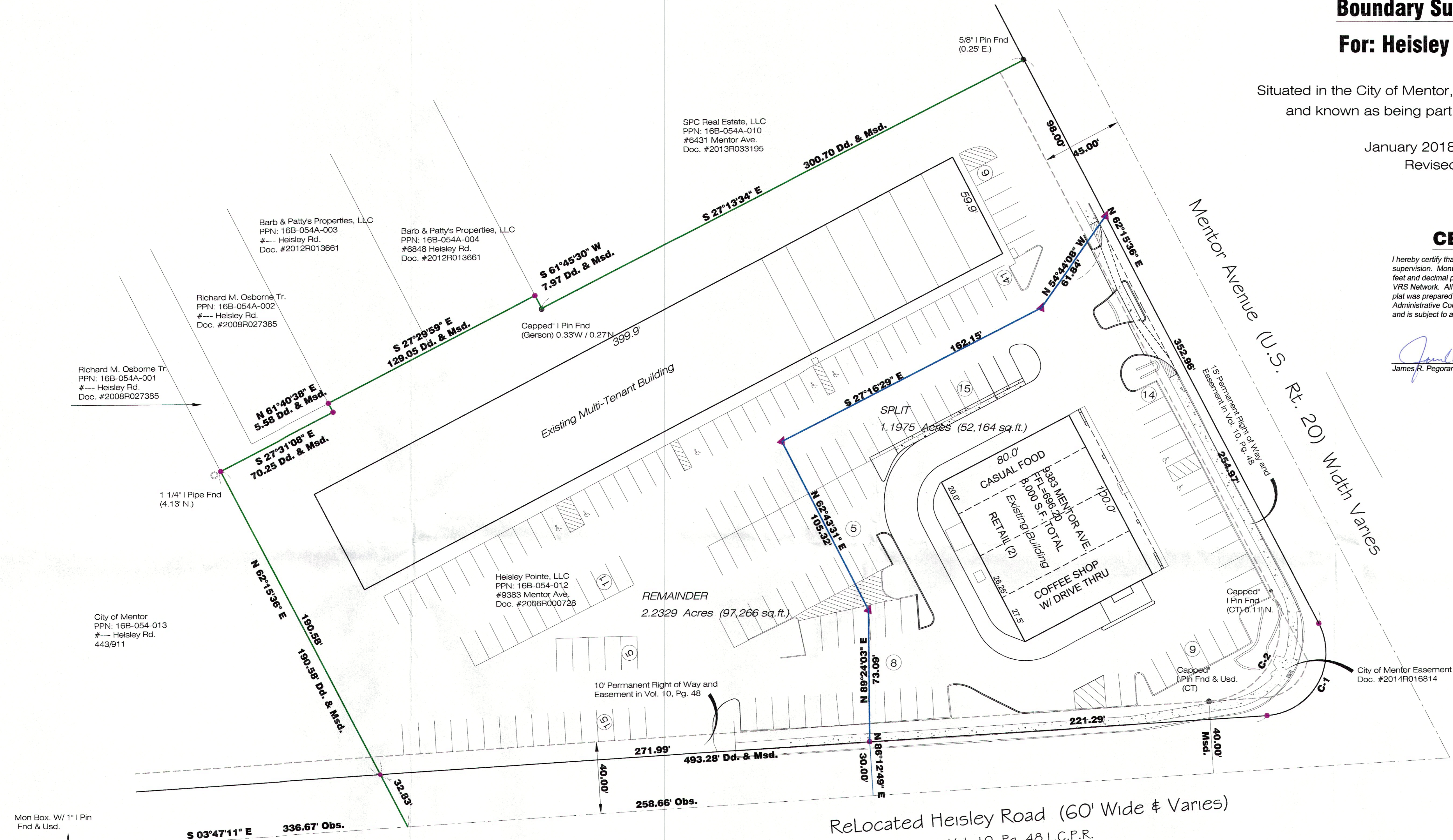

CURVE TABLE					
CURVE	LENGTH	RADIUS	CHORD	DELTA	BEARING
C-1	69.61	35.00	58.69	113°56'57"	N60°45'47"W
C-2	83.53	42.00	70.43	113°57'13"	N60°45'47"W

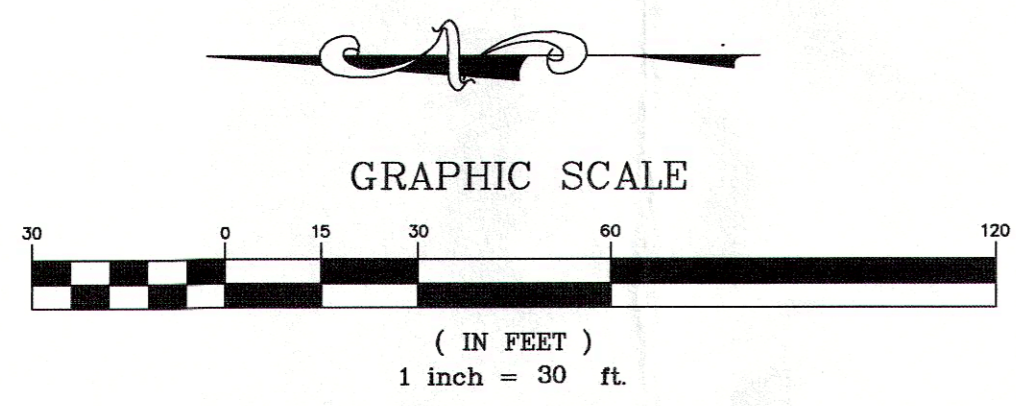

- ### Legend:
- I. Pin Found
 - I. Pipe Found
 - I. Pin Set
 - ⊠ Monument Box Found
 - Monument Box Empty
 - ▲ PK Set
 - ⊙ Stone Found
 - ⊕ Drill Hole Found
 - ⊕ Drill Hole Set
 - ⊙ Horizontal Control Point
 - ⊙ Vertical Control Point
 - ⊕ Hub Found
 - ⊕ Hub Set
 - ⊕ Railroad Spike Found
 - ⊕ Railroad Spike Set
 - ⊕ 5/8" Iron Pin Set (ID: LDC, Inc.)
 - ▲ P.K. Nail Set
 - Meas. = Measured
 - Plat = Subdivision Plat
 - D.M. = Deed & Measured
 - Dd. = Deed
 - Rec. = Record
 - Act. = Actual

REV. No.	DATE	BY	CHKD

LAND DESIGN consultants
www.LDCinc.net
ENGINEERS PLANNERS SURVEYORS
9025 Osborne Drive Mentor, Ohio 44060
TEL: (440) 255-9469 (440) 951-LAND
(440) 354-8938 FAX: (440) 255-9575

Heisley Pointe, LLC
9383 Mentor Ave.
City of Mentor - Lake County - Ohio

DATE 04-11-2018
SCALE: HOR. 1"=30'
VERT. _____
FILENAME Split
COMPUTER S: _____
TAB NAME Plat(2)

Lot Split - PPN: 16B-054-0-00-012-0

SHEET	OF
1	1
CONTRACT No.	
SEQR1-1701	