

**TOTAL ACREAGE 79.907 ACRES**  
**ACRES IN R/W FOR VALENTINE 0.554 ACRES**  
**ACRES IN R/W FOR LEROY-THOMPSON 0.042 ACRES**  
**NET 79.311 ACRES**

I, WILLIAM C. BABCOCK, P.S. #6528, DO HEREBY CERTIFY THAT THE SURVEY PERFORMED IS PURSUANT TO THE STATE OF OHIO ADMINISTRATIVE CODE STANDARDS SET FORTH AS PER ARTICLE NUMBER 4733-37.

*William C. Babcock* 1-7-16  
 WILLIAM C. BABCOCK, P.S. #6528 DATE:

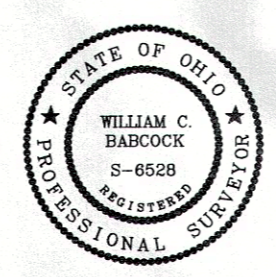

EXISTING UTILITIES NOTE: THE SIZE AND LOCATION, BOTH HORIZONTAL AND VERTICAL OF THE UNDERGROUND UTILITIES SHOWN HEREON, HAVE BEEN OBTAINED BY A SEARCH OF AVAILABLE RECORDS. VERIFICATION BY FIELD OBSERVATION HAS BEEN CONDUCTED WHERE PRACTICAL. HOWEVER, BABCOCK LAND SURVEYORS DOES NOT GUARANTEE THE COMPLETENESS NOR ACCURACY THEREOF.

SITUATED IN THE TOWNSHIP OF LEROY, COUNTY OF LAKE AND THE STATE OF OHIO AND KNOW AS BEING PART OF LOT NOS. 31 AND 32

**BASIS OF BEARINGS:**  
 CENTERLINE OF VALENTINE, 60 FEET WIDE BEING S 87° 00' 00" W USED TO DESCRIBE ANGLES ONLY.

**SURVEY REFERENCE:**  
 BABCOCK, JONES & ASSOCIATE SURVEY, 2002  
 CRABBS SURVEY FOR RICHARD F. POTTS, 1939  
 LAKE COUNTY ROAD RECORD, 1844  
 AAA LAND SURVEYING, INC., JUNE 2006  
 BABCOCK LAND SURVEYORS, INC., NOVEMBER 2013

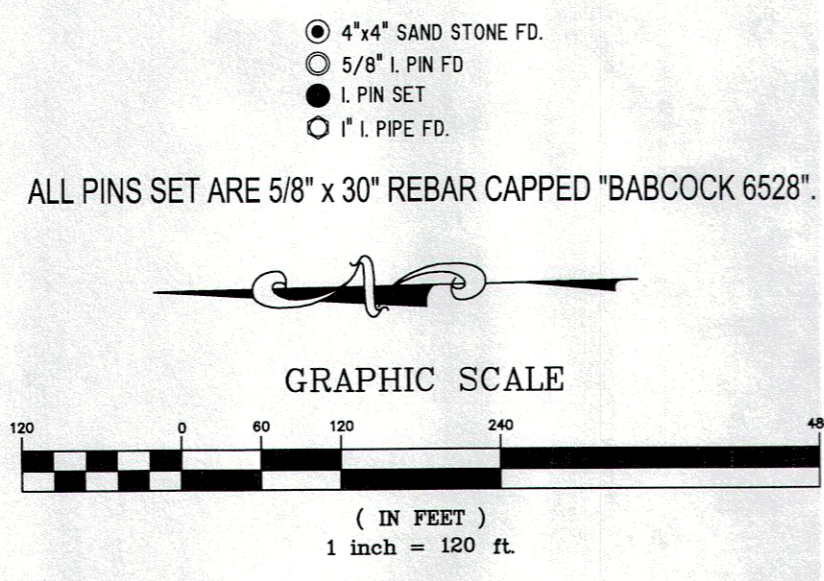

ALL BEARINGS AND DISTANCES OBSERVED

LINE	BEARING	DISTANCE
L1	N 02°58'35" W	43.25'
L2	N 50°27'13" W	105.00'
L3	N 28°41'45" E	61.09'
L4	S 02°27'10" E	143.09'
L5	S 02°58'35" E	66.52'
L6	S 60°17'45" E	59.02'
L7	S 89°28'40" E	53.36'
L8	S 77°01'00" E	70.15'
L9	N 86°45'40" E	80.02'
L10	N 62°08'40" E	59.52'
L11	N 22°51'55" W	40.49'

REV. NO.	DESCRIPTION	DATE	BY	CHK'D

**BABCOCK LAND SURVEYORS**  
 SURVEYORS & LAND PLANNERS  
 PAINESVILLE OHIO 44077  
 babcocklandsurveyors@yahoo.com

DATE 1/5/16  
 DESIGN BY R.B.  
 DRAWN BY W.S.O.  
 APPROVED BY W.B.

PLAT OF SURVEY FOR RONALD LORENZO  
 P.P. No. 07-A-008-E-00-004-0  
 LEROY TOWNSHIP LAKE COUNTY STATE OF OHIO

SCALE 1"=120'  
 JOB NO 15-69  
 SHEET 1 OF 1